

VIKING ACCESS SYSTEMS™

installation instructions

and safety information



**high-traffic commercial
barrier gate operator**



The B-12™ brings more Viking ingenuity to the gate operator industry. This machine exhibits it's high quality design and construction with it's smooth, efficient operation of the barrier arm. The innovation in design and operation provide a true backup function using batteries integrated directly in the system. The B-12™ can handle arms up to 16 feet long with operating speeds of up to 2 seconds per opening.

the viking B-12™ barrier gate operation

TABLE OF CONTENTS

Parts Diagram/Parts List	ii-1
Important Safety Information	
Important Safety Instructions	2
Important Installation Instructions	2-3
Maintenance/General Safety Precautions	4
Terminology	5
Photo Beam (non-contact sensor) Installation	6
Edge Sensor (contact sensor) Installation	7
Manual Release	7
Warning Placard Installation	9
Important Installation Information	9
Specifications	9
Plan of Installation – Concrete Specifications	10
Plan of Installation – Arm Assembly	10
Arm Setup	
Strut Selection and Mounting Instructions	11-12
Electrical Installation	
Electrical Installation	13
Open Left/Open Right Setup	14
Limit Switch Adjustment	
Positive Stop Adjustment	15
Speed Control Adjustment	15
Limit Switch Adjustment	16
Modes of Operation	
Gate Operator Synchronization	16-17
Vehicular Loop Detector Installation	
“Trap” Configuration	18
Loop Configuration	19
Installation Guidelines	20
Accessory Connections	
Open Commands; Safety Connections	21
Radio Receiver	22
Guard Station; Hold Open Timer	23
Special Features	
Auto Open Feature	24
Intelligent Obstruction Sensor	25
Solar Panel Installation	26
Optional Lighting	27
Optional VikingBlue Installation	28-29
Optional Articulated Arm Installation	30
Troubleshooting	31-32



PARTS LIST

**WARNING - For Installation
By Qualified Personnel Only.**

Item	Description	Part No.
1	Top PCB Cover	VAB12C
2	Top PCB Cover Hardware	VAB12CHD
3	Top PCB Cover Release	VAB12CR
4	Loop Rack	VA-LR
5	Control Board	DUPCB10-B12
6	PCB Chassis	VAB12CH
7	PCB Chassis Bracket (set)	VAB12CHB
8	Battery	DUBA12
9	Limit Harness	VAB12LH
10	Power Harness	VAB12PH
11	Kill Switch Harness	VAB12KSH
12	Arm Bracket Inner-Aluminum	VAB12ABI
13a	Arm Bracket Outer-Aluminum	VAB12ABO
13b	Arm Bracket Outer-Wooden	VAB12ABO-W
14	Arm Bracket Cover	VAB12ABC
15	Arm Edge Protector	VAB12AEPM
16	Arm End Cap	VAB12AECM
17	Arm - Aluminum 12'	VA-B12ARM12
18	Arm - Aluminum 16'	VA-B12ARM16
19	Arm - Wooden 14'	VA-B12ARM14
20	Barrier Cabinet	VAB12BC
21	Barrier Cabinet Front Panel	VAB12CFP
22	Barrier Cabinet Front Panel Hardware	VAB12CFPH
23	Barrier Cabinet Front Panel Bezel	VAB12CFPB
24	Barrier Cabinet Key	VAB12K
25	Barrier Cabinet Key Cylinder	VAB12KC
26	Barrier Cabinet Key Release Handle	VAB12KRH
27	Kill Switch	VAB12KS
28	Limit Switch	VAB12LS
29	Limit Switch Holder	VAB12LSH
30	Limit Cam	VAB12LC
31	Rocker Arm	VAB12RA
32	Positive Stop Nut and Bolt	VAB12PSHK
33	Spring Bolt & Washer	VAB12SH
34	Spring - Gray	VAB12SGY
35	Spring - Green	VAB12SGN
36	Spring - Red	VAB12SRD
37	Motor	VAB12MO
38	Gear Box	VAB12GB
39	Toroid Transformer	DUTT10
40	Accessory Shelf	VAB12AS
41	EMI Board	DUEMI10
42	EMI J-Box	VAB12EMIB
43	120V Receptacle	DUOL120
44	Attachment Bar (set)	VAB12AB
45	Circuit Breaker	DUMRS10
46	Warning Placard	DUWPA

Arm Dimensions

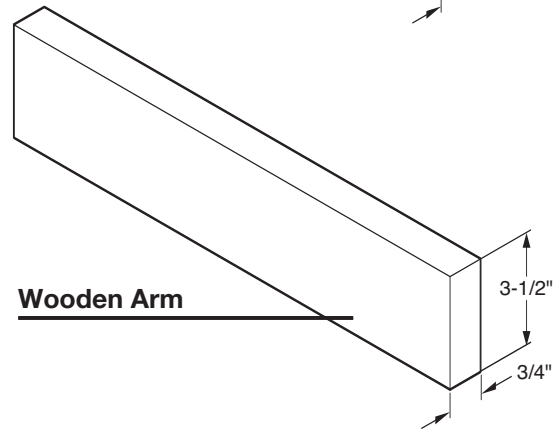
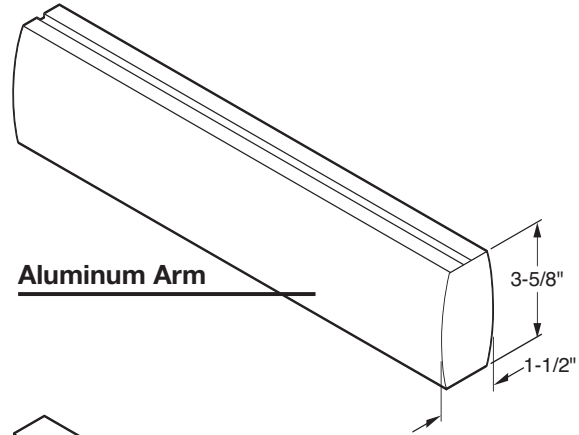

Overall Dimensions

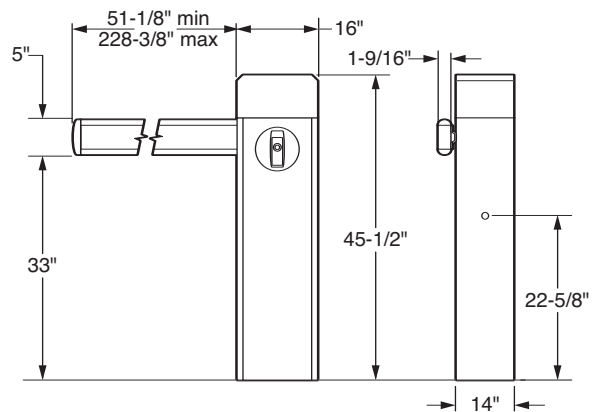

Weight

170 lb.



PARTS DIAGRAM

Aluminum Arm

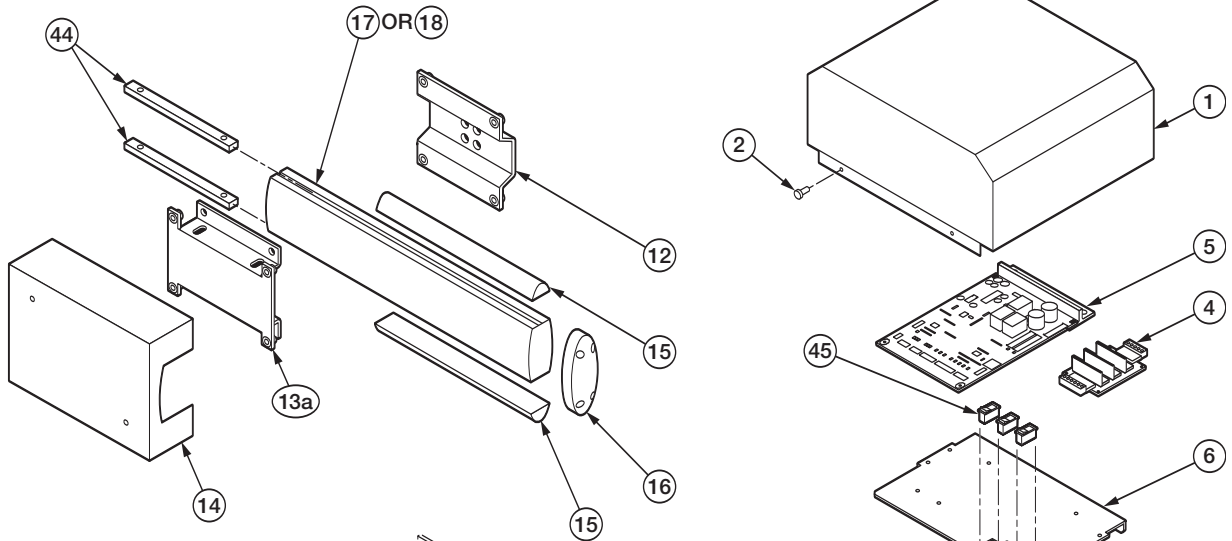

Wooden Arm

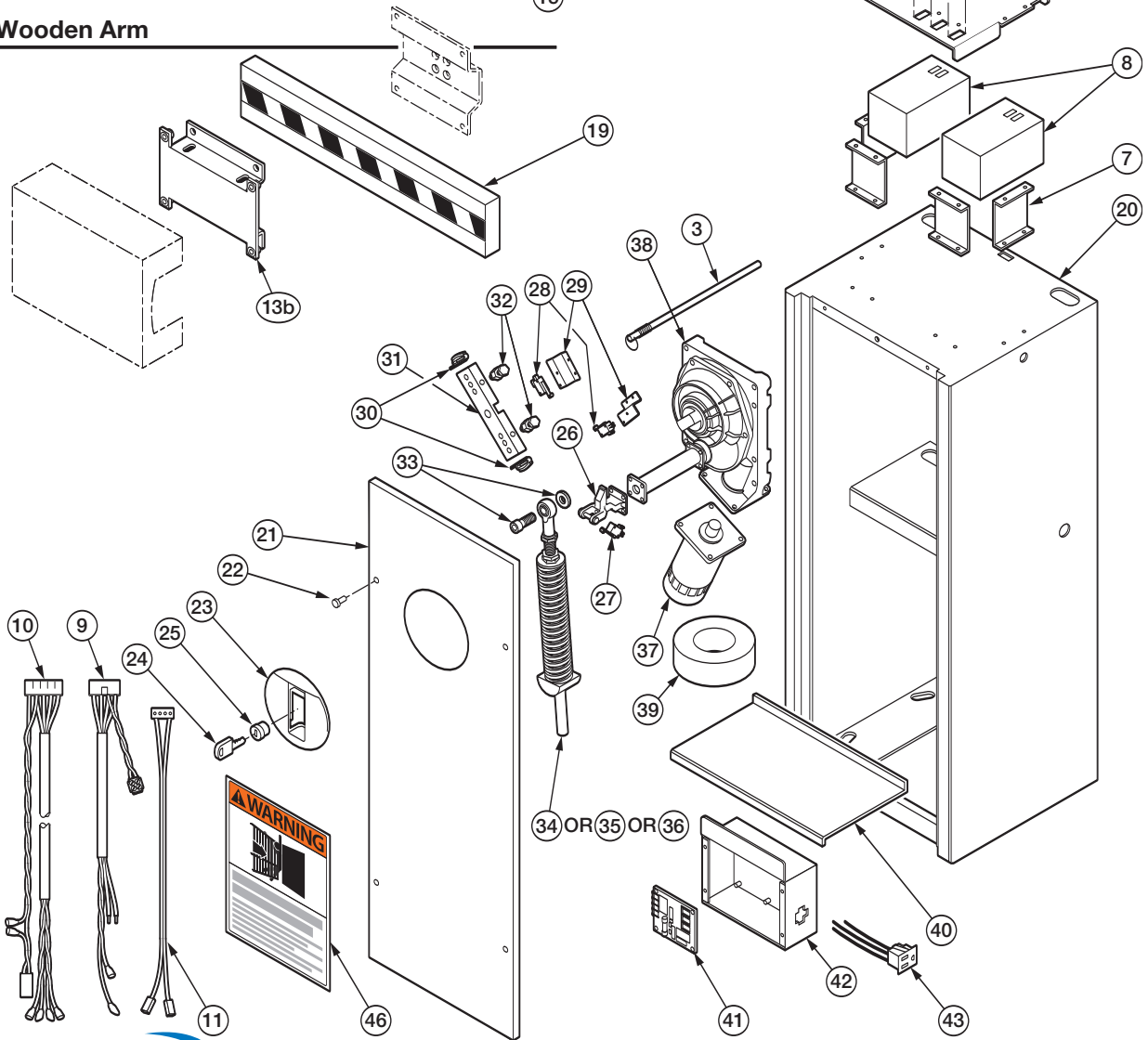

IMPORTANT SAFETY INFORMATION

WARNING - Not following these instructions may cause severe injury or death to persons.

IMPORTANT SAFETY INSTRUCTIONS

WARNING – To reduce the risk of severe injury or death:

1. READ AND FOLLOW ALL INSTRUCTIONS.
2. Never let children operate or play with gate controls. Keep the remote control away from children.
3. Always keep people and objects away from the gate. **NO ONE SHOULD CROSS THE PATH OF THE MOVING GATE.**
4. Test the gate operator monthly. The gate **MUST** reverse on contact with a rigid object or when an object activates the non-contact sensors. After adjusting the force or the limit of travel, retest the gate operator. Failure to adjust and retest the gate operator properly can increase the risk of injury or death.
5. Use the manual release only when the gate is not moving.
6. **KEEP GATES PROPERLY MAINTAINED.** Read the owner's manual. Have a qualified service person make repairs to gate hardware.
7. The entrance is for vehicles only. Pedestrians must use separate entrance.
8. **Every gate operator installation MUST have secondary protection devices against entrapment, such as edge sensors and photo beams more in particularly in places where the risk of entrapment is more likely to occur.**
9. SAVE THESE INSTRUCTIONS.

IMPORTANT INSTALLATION INSTRUCTIONS

1. Install the gate operator only when:
 - a) The operator is appropriate for the construction of the gate and the usage Class of the gate (refer to page 5),
 - b) All openings of a horizontal slide gate are guarded or screened from the bottom of the gate to a minimum of 4 feet (1.22 m) above the ground to prevent a 2-1/4 inch (57.2 mm) diameter sphere from passing through the openings anywhere in the gate, and in that portion of the adjacent fence that the gate covers in the open position,
 - c) **ALL EXPOSED PINCH POINTS ARE ELIMINATED OR GUARDED, AND**
 - d) **GUARDING IS SUPPLIED FOR EXPOSED ROLLERS.**
2. The operator is intended for installation only on gates used for vehicles. Pedestrians must be supplied with a separate access opening. The pedestrian access opening shall be designed to promote pedestrian usage. Locate the gate such that persons will not come in contact with the vehicular gate during the entire path of travel of the vehicular gate.
3. The gate must be installed in a location so that enough clearance is supplied between the gate and adjacent structures when opening and closing to reduce the risk of entrapment. Swinging gates shall not open into public access areas.
4. The gate must be properly installed and work freely in both directions prior to the installation of the gate operator. Do not over-tighten the operator clutch or pressure relief valve to compensate for a damaged gate.
5. The gate operator controls must be placed so that the user has full view of the gate area when the gate is moving **AND AWAY FROM THE GATE PATH PERIMETER.**
6. Controls intended for user activation must be located at least six feet (6') away from any moving part of the gate and where the user is prevented from reaching over, under, around or through the gate to operate the controls. Outdoor or easily accessible controls shall have a security feature to prevent unauthorized use.



IMPORTANT SAFETY INFORMATION

WARNING - Not following these instructions may cause severe injury or death to persons.

IMPORTANT INSTALLATION INSTRUCTIONS Continued

7. The Stop and/or Reset button must be located in the line-of-sight of the gate. Activation of the reset control shall not cause the operator to start.
8. All warning signs and placards must be installed where visible in the area of the gate. A minimum of two placards shall be installed. A placard is to be installed in the area of each side of the gate and be visible to persons located on the side of the gate on which the placard is installed.
9. **For gate operators utilizing a non-contact sensor (Photo beam or like) in accordance with section 31.1.1 of the UL325 standard:**
 - a) **See instructions on the placement of non-contact sensors for each Type of application (refer to page 6),**
 - b) **Care shall be exercised to reduce the risk of nuisance tripping, such as when a vehicle, trips the sensor while the gate is still moving, and**
 - c) **One or more non-contact sensors shall be located where the risk of entrapment or obstruction exists, such as the perimeter reachable by a moving gate or barrier (refer to page 6).**
 - d) **Use only Omron E3K-R10K4 photoelectric eye to comply with UL325**
 - e) **One or more non-contact sensors shall be located where the risk of entrapment or obstruction exists, such as the perimeter reachable by a moving gate or barrier.**
10. **For a gate operator utilizing a contact sensor (Edge sensor or like) in accordance with section 31.1.1 of the UL325 standard:**
 - a) **One or more contact sensors shall be located where the risk of entrapment or obstruction exists, such as at the leading edge, trailing edge, and post mounted both inside and outside of a vehicular horizontal slide gate (refer to page 7).**
 - b) **One or more contact sensors shall be located at the bottom edge of a vehicular vertical lift gate.**
 - c) **One or more contact sensors shall be located at the pinch point of a vehicular vertical pivot gate.**
 - d) **A hardwired contact sensor shall be located and its wiring arranged so that the communication between the sensor and the gate operator is not subjected to mechanical damage.**
 - e) **A wireless contact sensor such as one that transmits radio frequency (RF) signals to the gate operator for entrapment protection functions shall be located where the transmission of the signals are not obstructed or impeded by building structures, natural landscaping or similar obstruction. A wireless contact sensor shall function under the intended end-use conditions.**
 - f) **One or more contact sensors shall be located on the inside and outside leading edge of a swing gate. Additionally, if the bottom edge of a swing gate is greater than 6 inches (152 mm) above the ground at any point in its arc of travel, one or more contact sensors shall be located on the bottom edge (refer to page 7).**
 - g) **One or more contact sensors shall be located at the bottom edge of a vertical barrier (arm).**
 - h) **Use only Miller Edge Model MGR20 or MGS20 edge sensor to comply with UL325**



IMPORTANT SAFETY INFORMATION

WARNING - Not following these instructions may cause severe injury or death to persons.

MAINTENANCE

Remove the Power Harness from the Control Board (refer to page 17)

- Clean and lubricate the turning pins and gate hinges using the recommended lubricant.
- Check that all mounting hardware of the gate operator is properly tighten.
- Ensure that the gate moves freely.
- Check for corroded parts and replace if necessary.
- Check the battery for the following:
 - Battery connections must be free of corrosion.
 - Battery voltage must be 26 VDC (fully charged battery).

Reconnect the Power Harness for the Control Board (refer to page 17)

- Check and confirm the proper operation of all safety devices (photoelectric eye, edge sensors or like).
- Check and confirm the operation of all installed accessories.
- Check and confirm the operation of all special features such as the Intelligent Obstruction Sensor, Hold Open Timer (refer to page 20 to 27)
- Check and confirm the operation of the manual release (refer to page 7)
- Verify battery backup functionally by turning off the power source (120 VAC and 220 VAC). DO NOT FORGET TO TURN ON THE POWER SOURCE AFTER VERIFICATION.

GENERAL SAFETY PRECAUTIONS

The following precautions are an integral and essential part of the product and must be supplied to the user. Read them carefully as they contain important indications for the safe installation, use and maintenance.

- These instruction must be kept and forwarded to all possible future users of the system.
- This product must be used only for that which it has been expressly designed.
- Any other use is to be considered improper and therefore dangerous.
- The manufacturer cannot be held responsible for possible damage caused by improper, erroneous or unreasonable use.
- Avoid operating in the proximity of the hinges or moving mechanical parts.
- Do not enter the path of the moving gate while in motion.
- Do not obstruct the motion of the gate as this may cause a situation of danger.
- Do not allow children to play or stay within the the path of the moving gate.
- Keep remote control or any other control devices out of the reach of children, in order to avoid possible involuntary activation of the gate operator.
- In case of break down or malfunctioning of the product, disconnect from the main power source. Do not attempt to repair or intervene directly, contact only qualified personnel for repair.
- Failure to comply with the above may create a situation of danger.
- All cleaning, maintenance or repair work must be carried out by qualified personnel.
- In order to guarantee that the system works efficiently and correctly it is important to have the manufacturer's instructions on maintenance of the gate and operator carried out by qualified personnel.
- In particular, regular checks are recommended in order to verify that the safety devices are operating correctly.

All installation, maintenance and repair work must be documented and made available to the user.

Installer:

Signature

Date

Contact:



IMPORTANT SAFETY INFORMATION

CAUTION: To Reduce the Risk of Fire or Injury to Persons

- a) Use only the following type and size of battery(ies): Yuasa NP7-12
- b) Do not dispose of the battery(ies) in fire. The cells may explode. Check with local codes for possible disposal instructions.
- c) Do not open or mutilate the battery(ies). Released electrolyte is corrosive and may cause damage to the eyes or skin. It may be toxic if swallowed.
- d) Exercise care in handling batteries in order not to short the battery with conducting materials such as rings, bracelets and keys.
- e) Change the battery(ies) provided with or identified for use with this product only in accordance with the instructions and limitations specified in this manual.
- f) Observe proper polarity orientation between the battery(ies) and charging circuit.
- g) Do not mix batteries of different sizes or from different manufacturers in this product (applies to products employing more than one user replaceable secondary battery).
- h) A battery-operated product employing a secondary battery supply intended to be charged within the product shall contain specific instructions concerning the proper method of charging.

UL325 Gate Operator Classification

GLOSSARY

RESIDENTIAL VEHICULAR GATE OPERATOR

CLASS I – A vehicular gate operator (or system) intended for use in a home of one-to four single family dwelling, or a garage or parking area associated therewith.

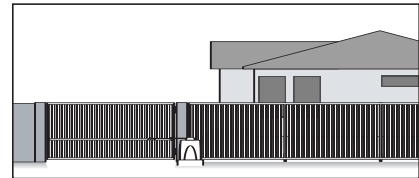

COMMERCIAL/GENERAL ACCESS VEHICULAR GATE OPERATOR

CLASS II – A vehicular gate operator (or system) intended for use in a commercial location or building such as a multi-family housing unit (five or more single family units), hotel, garages, retail store, or other building servicing the general public.

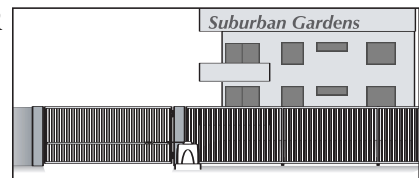

INDUSTRIAL/LIMITED ACCESS VEHICULAR GATE OPERATOR

CLASS III – A vehicular gate operator (or system) intended for use in an industrial location or building such as a factory or loading dock area or other locations not intended to service the general public.

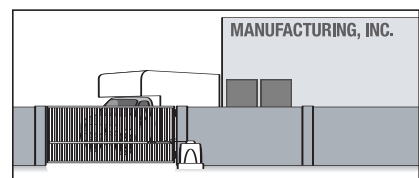

RESTRICTED ACCESS VEHICULAR GATE OPERATOR

CLASS IV – A vehicular gate operator (or system) intended for use in a guarded industrial location or building such as an airport security area or other restricted access locations not servicing the general public, in which unauthorized access is prevented via supervision by security personnel.

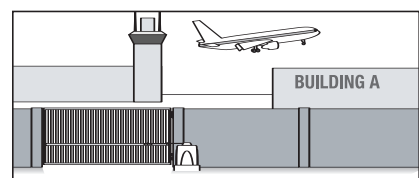

Install the gate operator only when:

The operator is appropriate for the construction of the gate and the Usage Class of the gate.



IMPORTANT SAFETY INFORMATION

WARNING - Not following these instructions may cause severe injury or death to persons.

Photo Beam (non-contact sensor) Installation Re-Open Sensor

Photo beams or like must be installed to reduce the risk of entrapment.

Use only Omron E3K-R10K4 photoelectric eye to comply with UL325

Make the electrical connections of the photoelectric sensor as described here in this page.

Care shall be exercised to reduce the risk of nuisance tripping, such as when a vehicle, trips the sensor while the gate is still moving, and

One or more non-contact sensors shall be located where the risk of entrapment or obstruction exists, such as the perimeter reachable by a moving gate or barrier.

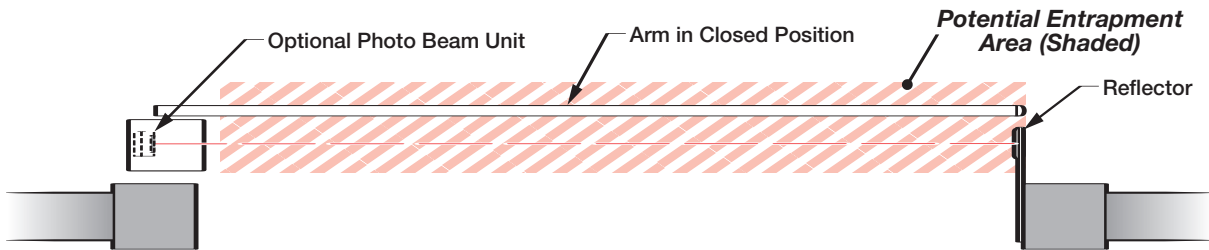
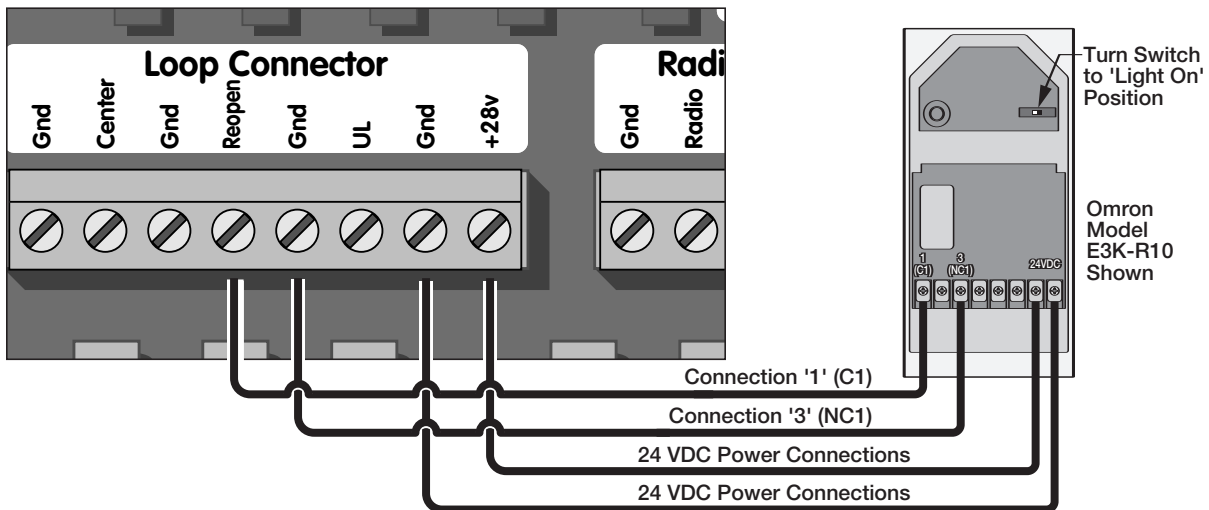

One or more non-contact sensors shall be located where the risk of entrapment or obstruction exists, such as the perimeter reachable by a moving gate or barrier.

Consult the installation manual for the UL325 device (photo beam or like) for detail information about the usage, installation and maintenance

IMPORTANT SAFETY INFORMATION

WARNING - Not following these instructions may cause severe injury or death to persons.

Edge Sensor (contact sensor) Installation Secondary Entrapment Protection

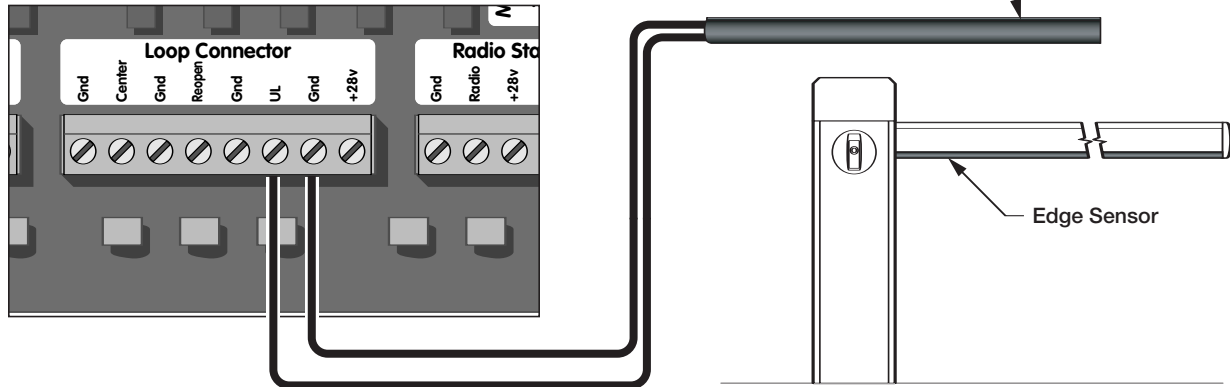

Edge sensor or like must be installed to reduce the risk of entrapment.

Use only Miller Edge 3-sided activation type MGR20 or MDS20 to comply with UL325. One or more non-contact sensors shall be located where the risk of entrapment or obstruction exists, such as the perimeter reachable by a moving gate or barrier.

1. A hardwired contact sensor shall be located and its wiring arranged so that the communication between the sensor and the gate operator is not subjected to mechanical damage.
2. A wireless contact sensor such as one that transmits radio frequency (RF) signals to the gate operator for entrapment protection functions shall be located where the transmission of the signals are not obstructed or impeded by building structures, natural landscaping or similar obstruction. A wireless contact sensor shall function under the intended end-use conditions.

Manual Release

When manual operation is required:
Secure the Arm to prevent sudden movement when releasing the Arm.

To activate the Manual Release – Insert the Key provided and rotate clockwise. Pull the Release Lever down.

To resume normal operation – Push the Release Lever to the vertical position. Turn the Key counterclockwise to relock.

Move the Arm until it locks into position.

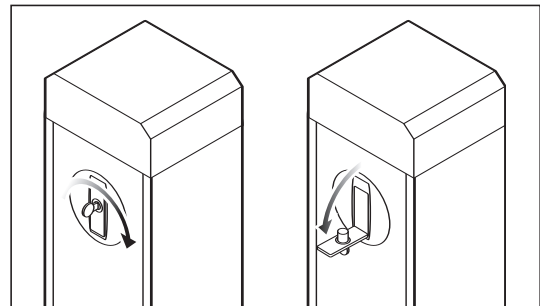

NOTE - Turning the Key and pulling the Release Lever will activate the Kill Switch and make the unit inoperable.

To operate the unit with the cover off the Lever must be closed and the Key relocked.





This page is intentionally left blank.



IMPORTANT INSTALLATION INFORMATION

WARNING - TO REDUCE THE RISK OF SEVERE INJURY OR DEATH TO PERSONS:

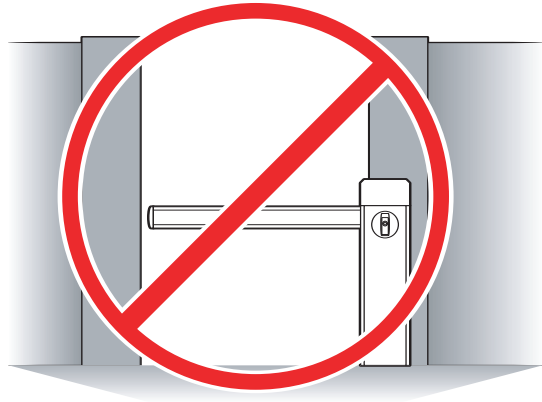

This is NOT a pedestrian gate operator

Specifications

Maximum Arm Length (wood):	14 feet
Maximum Arm Length (Aluminum):	16 feet
Maximum Speed:	2 seconds
Power Requirements:	120 VAC Single Phase at 3 Amps Or 220 VAC Single Phase at 1.5 Amp
Operating Temperature:	-20°C (-4°F) to 70°C (158°F)

Warning Placard Installation

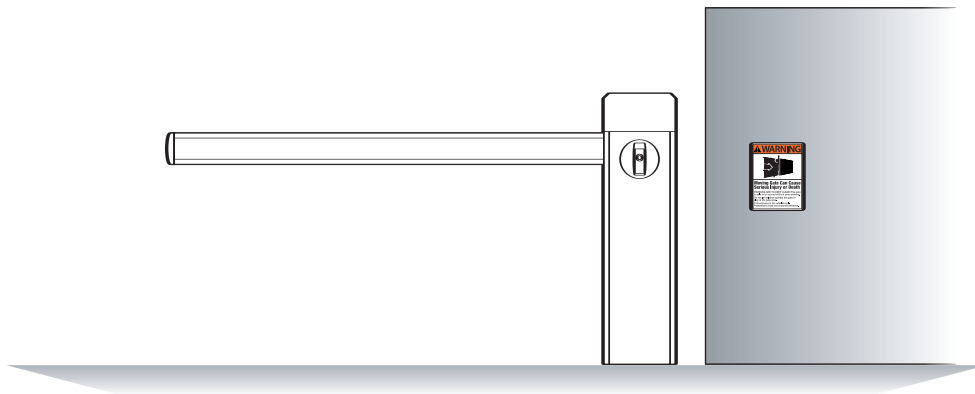

All Warning Signs and Placards must be installed where visible in the area of the gate. A minimum of two placards shall be installed. A placard is to be installed in the area of each side of the gate and be visible.



PLAN OF INSTALLATION

Concrete Specifications

1. Follow the local building code to determine the required depth of the concrete pad.
2. Pad measurements recommended by Viking Access Systems are at least 24" long, 18" wide and 24" deep to ensure the stable operation of the operator, and a minimum of 6" above level grade to avoid any flooding of the machinery.
4. Provide a sufficient number of conduit pathways for all low power accessories such as loop detector leads, maglock, non-contact sensors, contact sensors, safety and other commands. Also provide conduit for the power supply (either 110 or 220 VAC). Extend the conduit the recommended height of 1" above the level of the concrete pad. Install all conduit in the shaded area shown above.

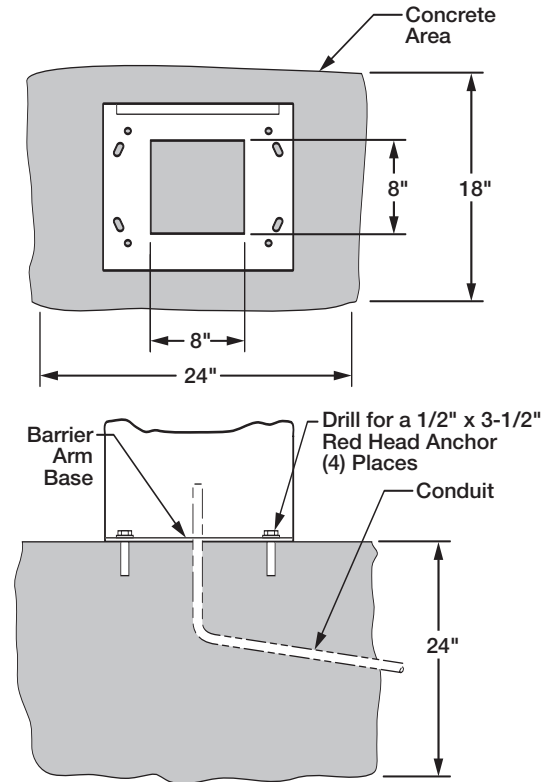

Assemble the Arm

Assemble the Arm as shown, using hardware provided.

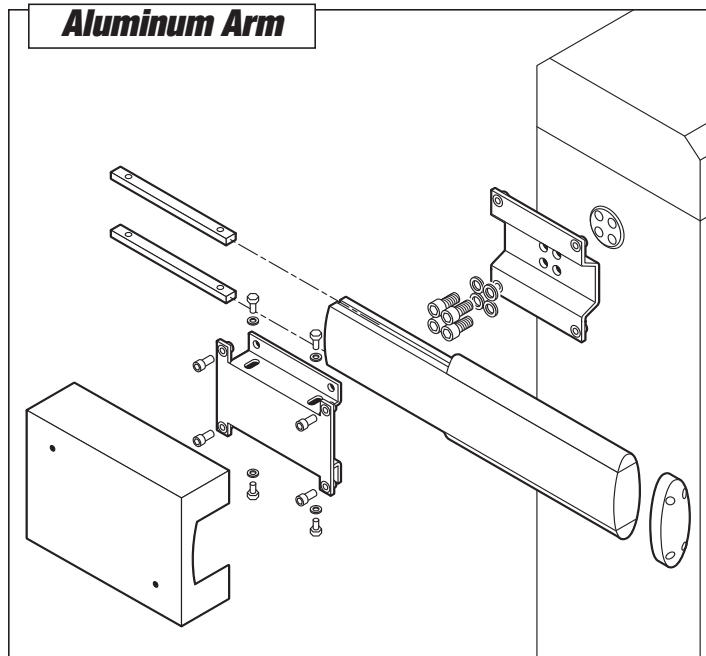
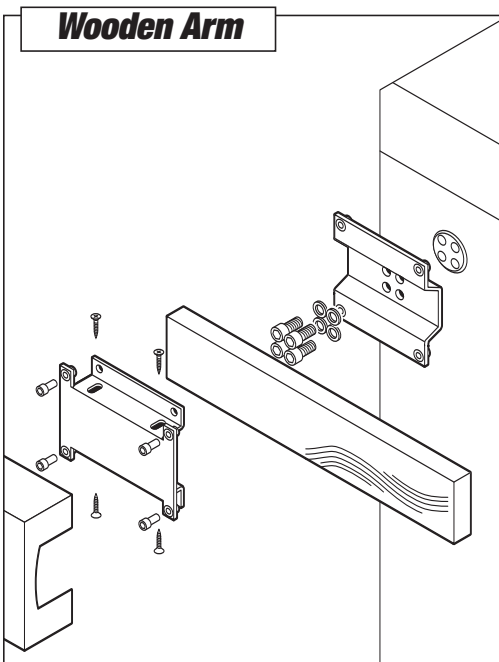

BARRIER ARM INSTALLATION

STEP 1

Select proper Strut and Mounting Position dependent on Arm length.

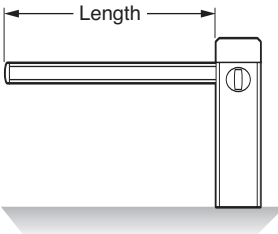
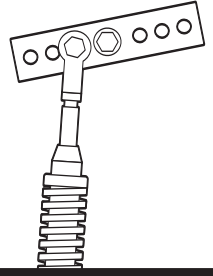
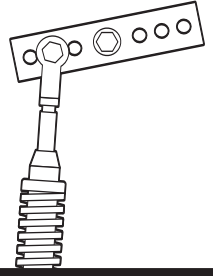
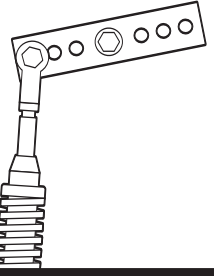
	Strut Mounting Position		
			
Aluminum Arm			
Arm Length (ft)	Strut Used	Strut Used	Strut Used
4.25 up to 5.5	Grey (VAB12SGY)	—	—
5.6 up to 6.5	—	Grey (VAB12SGY)	—
6.6 up to 8.0	Green (VAB12SGN)	—	—
8.1 up to 10.0	—	Green (VAB12SGN)	—
10.1 up to 12.0	—	—	Green (VAB12SGN)
12.1 up to 15.0	Red (VAB12SRD)	—	—
15.1 up to 17.0	—	Red (VAB12SRD)	—
Articulated Aluminum Arm			
6.5 up to 7.5	Green (VAB12SGN)	—	—
7.6 up to 9.5	—	Green (VAB12SGN)	—
9.6 up to 10.5	—	—	Green (VAB12SGN)
Wooden Arm			
Strut not needed for wooden arms up to 12' (as long as wood is not heavier than .45 lbs/foot or 5.4 lbs total)			
12.5 up to 14	—	—	Grey (VAB12SGY)

Strut Ordering Information

Strut Color	Grey	Green	Red
Viking Part No.	VAB12SGY	VAB12SGN	VAB12SRD



BARRIER ARM INSTALLATION

STEP 2

Manually release the motor as shown on page 7.

Place the Arm in the vertical position. Loosen the Jam Nut on the Strut.

Insert the Strut into the left or right pivot point (depending on opening direction).

Attach the Strut using the bolt and spacer provided into the proper mounting position (as selected in Step 1).

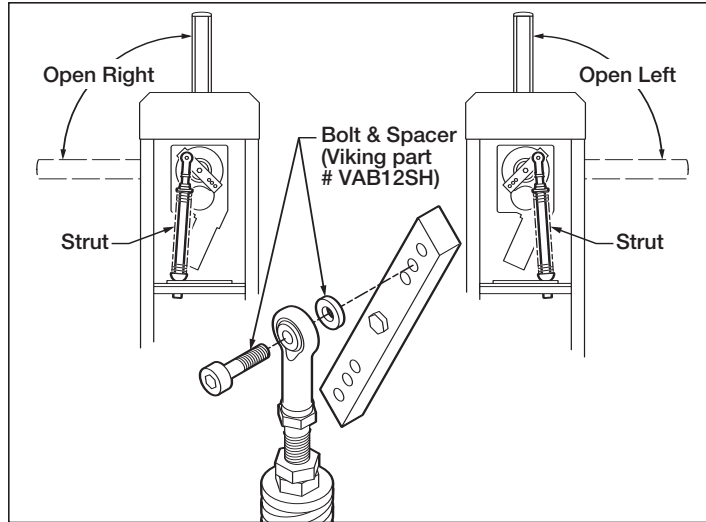

STEP 3

Balancing the Barrier Arm

Balance the Arm at an angle of 5° to 30° above the floor by compressing the Balancing Spring using the Adjusting Nut.

If properly adjusted, a balanced Arm will remain motionless at a 5° to 30° angle.

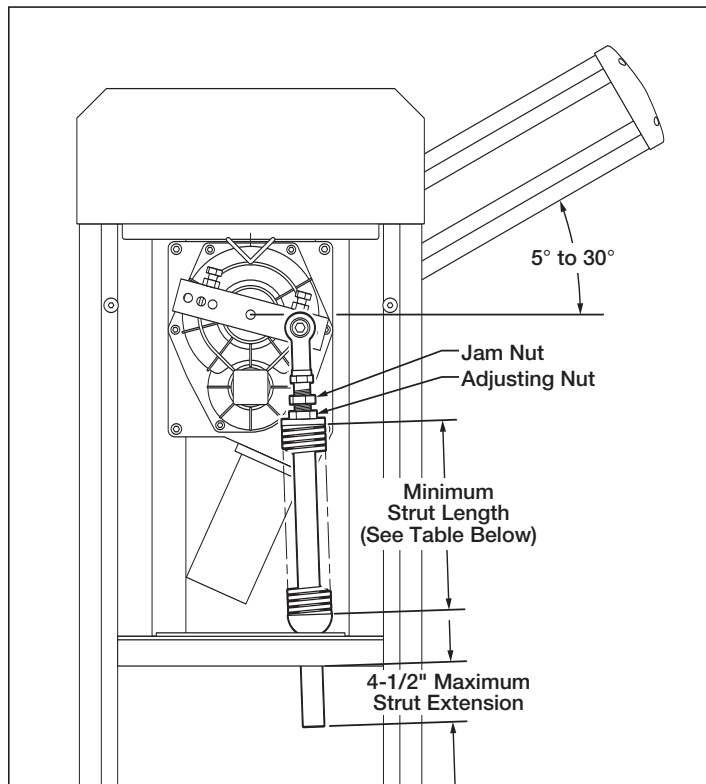

Warning

The Balancing Spring can not be compressed any shorter than the dimension shown on the table at the right.

STEP 4

Check that Arm remains motionless in the fully open and fully closed positions while in Manual Release mode.

Retighten the Jam Nut.

A Strut MUST BE USED for:

- An aluminum arm of any length or
- A wood arm longer than 12'

It is recommended to use a rest post for any arm over 14' long.

Minimum Strut Adjustment Length		
Strut Color	Viking Part #	Minimum Length
Grey	VAB12SGY	7.5"
Green	VAB12SGN	7.5"
Red	VAB12SRD	9.0"



ELECTRICAL INSTALLATION

Caution – Do not connect the power harness to the board until the installation is ready for verification.

Caution – Turn all the switches to off position before connecting power harness to the board.

The B-12 barrier arm operator requires a single phase AC line to operate and charge the batteries.

1. Turn off the main switch or breaker for the power line being used.
2. Move the selector switch on the Incoming Voltage Selector to the proper position (115 for 110 to 120VAC, 230 for 200 to 240VAC).
3. Connect the incoming power wires to the terminals as shown in the illustration.
4. Turn on the main switch or breaker once the installation is ready for performance check and adjustments.
5. Connect main power harness (as shown in picture).
6. Turn unit power switches to the reset position.
7. Verify that the green 'Charger' LED on the main circuit board is illuminated. If not, see page 30 for troubleshooting.

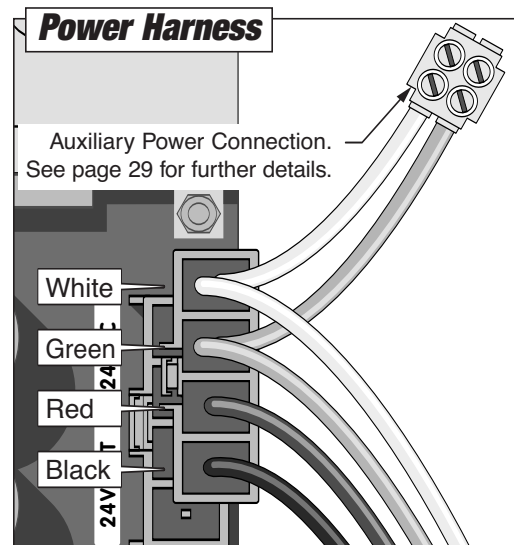
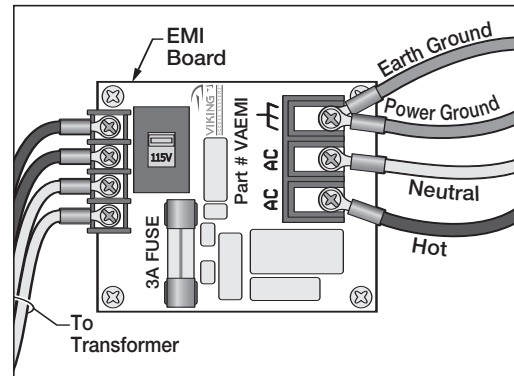
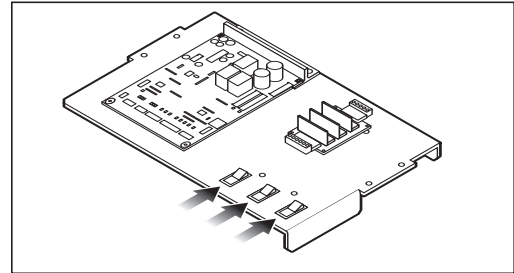

ELECTRICAL INSTALLATION

Connect the wire harness to the “OPEN RIGHT” connector if the arm opens towards the right side. Connect the wire harness to the “OPEN LEFT” connector if the arm opens towards the left side.

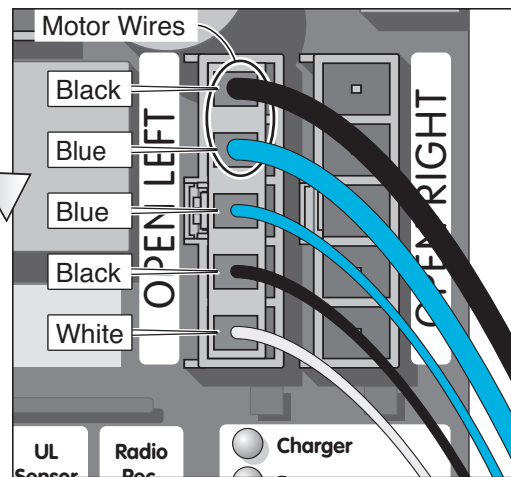
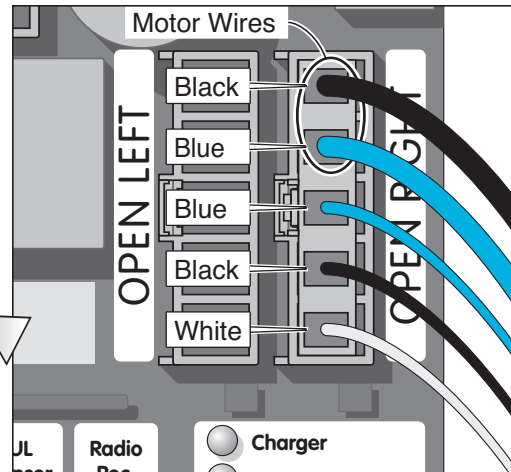
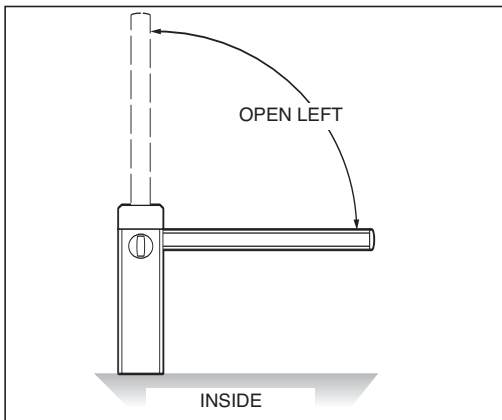
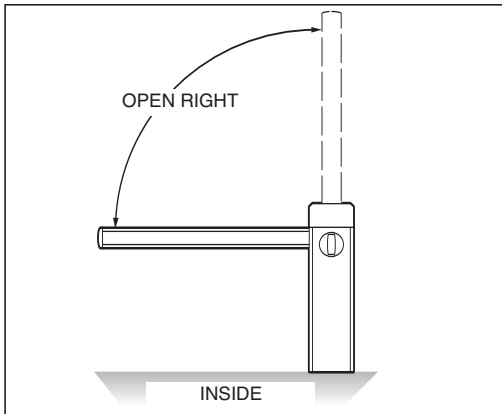

Tips for proper ground installation

A good ground in a gate operator installation will minimize or prevent damage to the operator cause by natural events such as lightning strikes.

The following will provide a guideline for proper grounding:

1. Use a ground rod to provide a ground reference.
2. Consult your city code and be aware of underground services in the site of the gate operator to prevent inconveniences.
3. Use always a single bonding point for grounding.
4. All ground wires must be as short and as thick as possible.
5. Prevent unnecessary turns or loops in all ground wires.

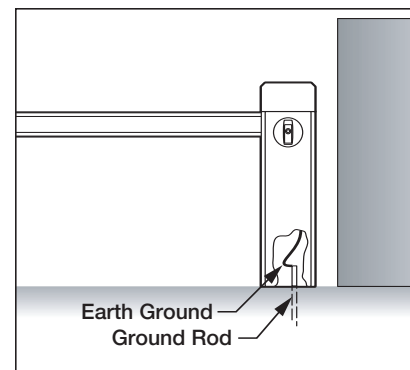

BARRIER ARM INSTALLATION

Caution

Set up the Barrier Arm travel limit in this order:

First: Adjust the positive stops

Second: Adjust the speed control

Third: Adjust the limit switches

Positive Stop Adjustment

Loosen the Jam Nuts on the Positive Stop Bolts.

Position the Arm in the fully open position. Tighten the Bolt against the Positive Stop.

Tighten the Jam Nut.

Position the Arm in the fully closed position. Tighten the Bolt against the Positive Stop.

Tighten the Jam Nut.

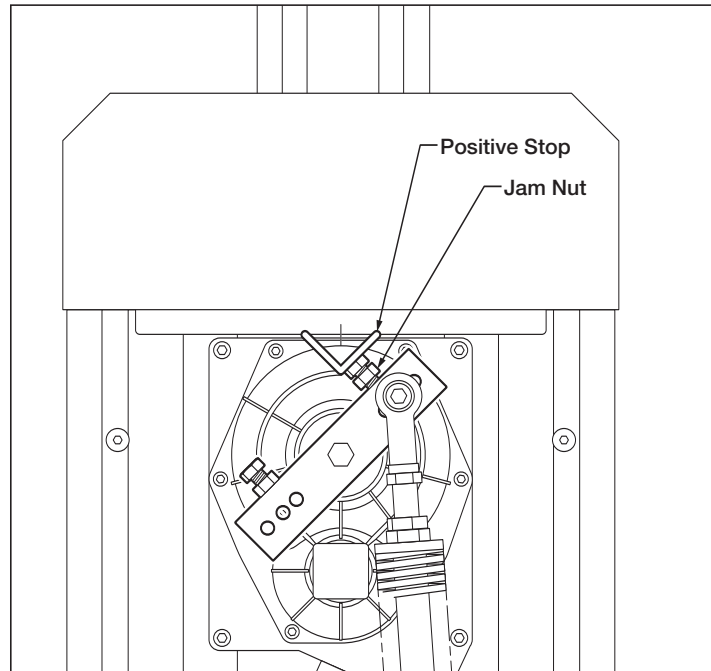

Speed Control Adjustment

The Speed Control Pot has a direct relation to the Limit Switch setup. The Barrier Control unit is shipped with this Pot set at its maximum speed. For a 12' or longer Arm, the speed will have to be reduced (by turning the pot adjuster clockwise) to achieve smooth action. Changing this setting will require resetting the Limit Switch Cams.

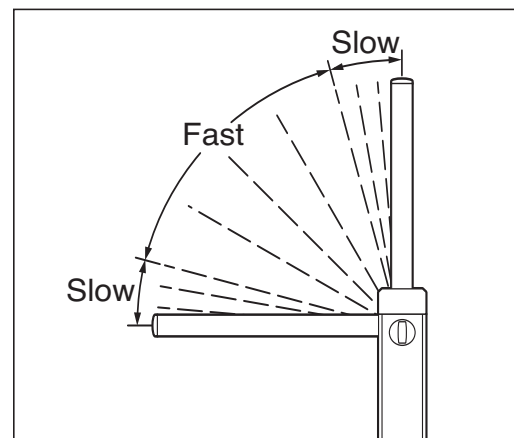
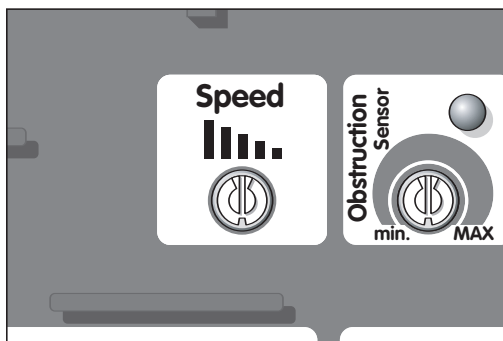

LIMIT SWITCH ADJUSTMENT

Be sure the power is connected and the Limit Connector is positioned properly for “Open Left” or “Open Right.”

1. With the Positive Stop properly set, manually move the Arm to the “Open” position. Set the Limit Cam so that it is centered on its related Limit Switch.
2. Move the Arm to the “Closed” position and repeat.
3. Run the Barrier Arm through 2 complete cycles to allow the board to ‘learn’ the position of the limit cams.
4. Adjust the cam(s) to achieve a very smooth stop in each position.

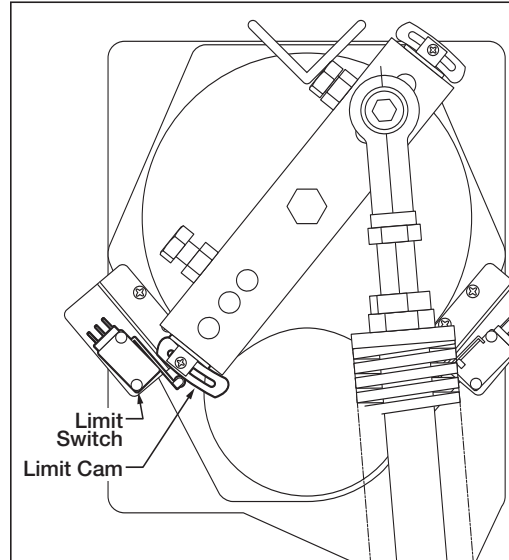

Warning

Be sure there is not too much stress placed on the Positive Stop. Re-adjust as necessary. Be sure all hardware is tightened properly.

GATE OPERATOR SYNCHRONIZATION

Operation:

The Barrier Arm operation can be synchronized with an existing Gate Operator

1. Viking B12 Barrier Arm receives an open command from your access control
2. Viking B12 Barrier Arm remains closed and sends an “open signal” to the synchronized operator
3. Viking B12 Barrier Arm will open once the synchronized operator reaches its open limit.

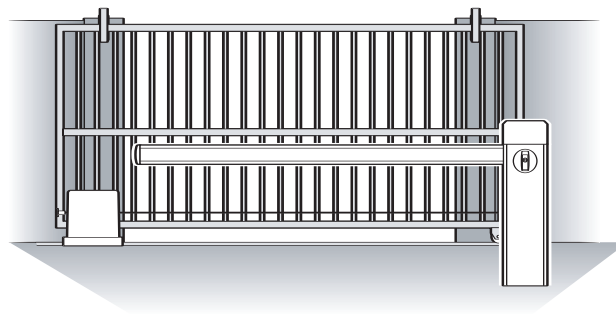

GATE OPERATOR SYNCHRONIZATION

Connections:

Connect the chosen access control accessory for control of the B12 Barrier Arm.

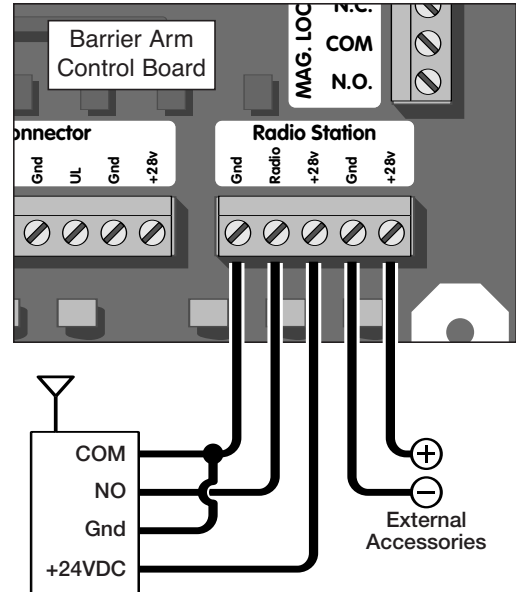

Connect the B12 Barrier Arm to the Gate Operator to be synchronized.

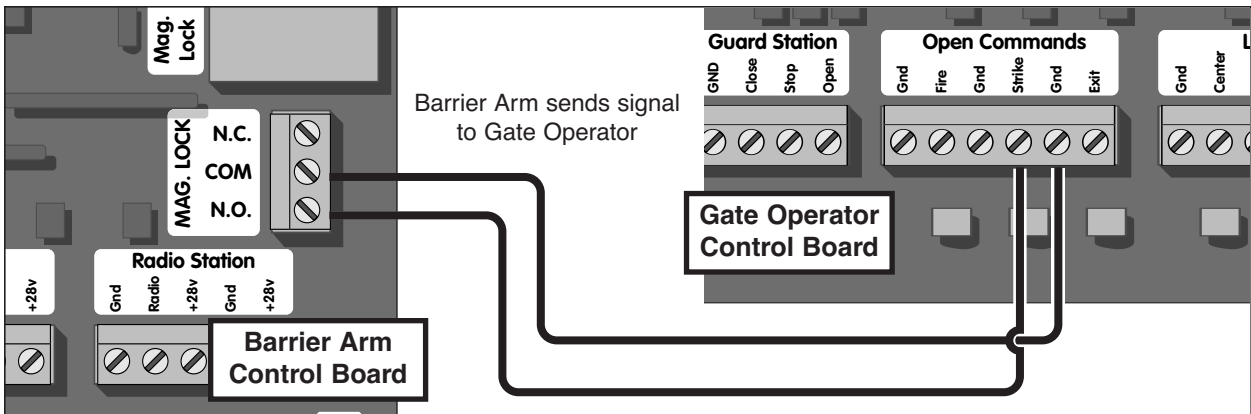

Connect the B12 Barrier Arm control board to the 'Open' limit switch.

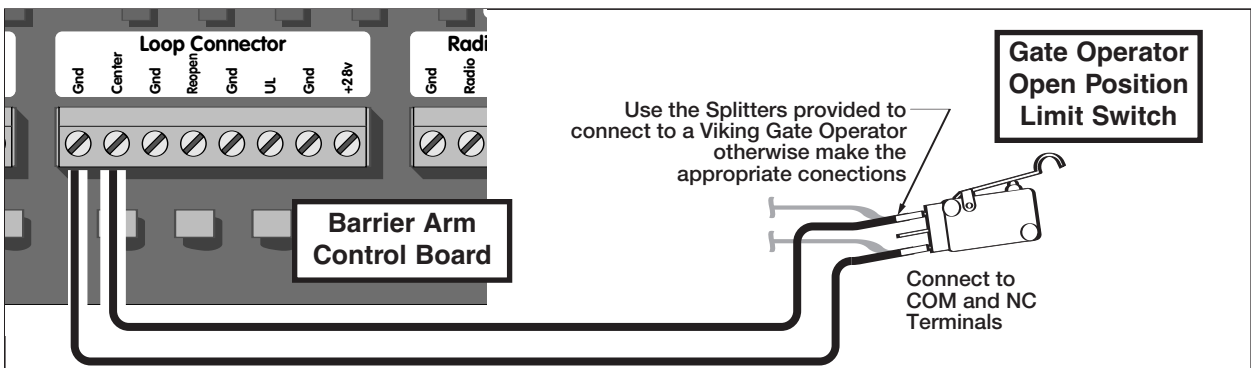

VEHICULAR LOOP DETECTOR INSTALLATION

“Trap” Configuration

Any Viking Access Systems operator can be used as the “Access Operator” in place of the B12 (depicted below). Positioning of the Reopen Loop for the “Access Operator” will vary depending on the type of operator used.

- Operation:**
1. “Trap Operator” opens when a command is given from your access control device
 2. Vehicle enters “Trap Loop”.
 3. Trap Operator will close after the vehicle clears its Reopen Loop, trapping vehicle.
 4. “Access Operator” opens as soon as the Trap Operator is fully closed, allowing access to the property.
 5. “Access Operator” will close after the vehicle clears its Reopen Loop.

- Setup:**
1. For the operators to close automatically, set the “Hold Open Timer” on both operators.
 2. Connect the N.O. contact of the Trap Operators closed limit switch to the “Trap Loop Detector”, relay Common contact.
 3. Connect the Trap Loop Detectors N.O. contact to the Access Operators “Open” terminal, found on the “Guard Station” connector.
 4. “Signal Ground” must be shared between both operators, by connecting the “GND” terminal, also found on the “Guard Station” connector, to both operators.

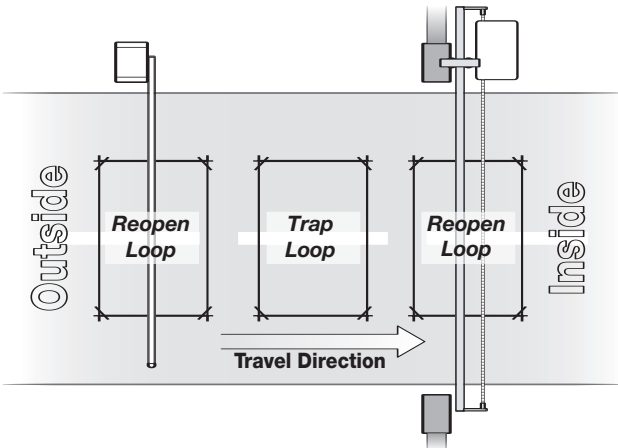

Notice:
The Trap loop detector required a DRY CONTACT output to be able to implement this function.

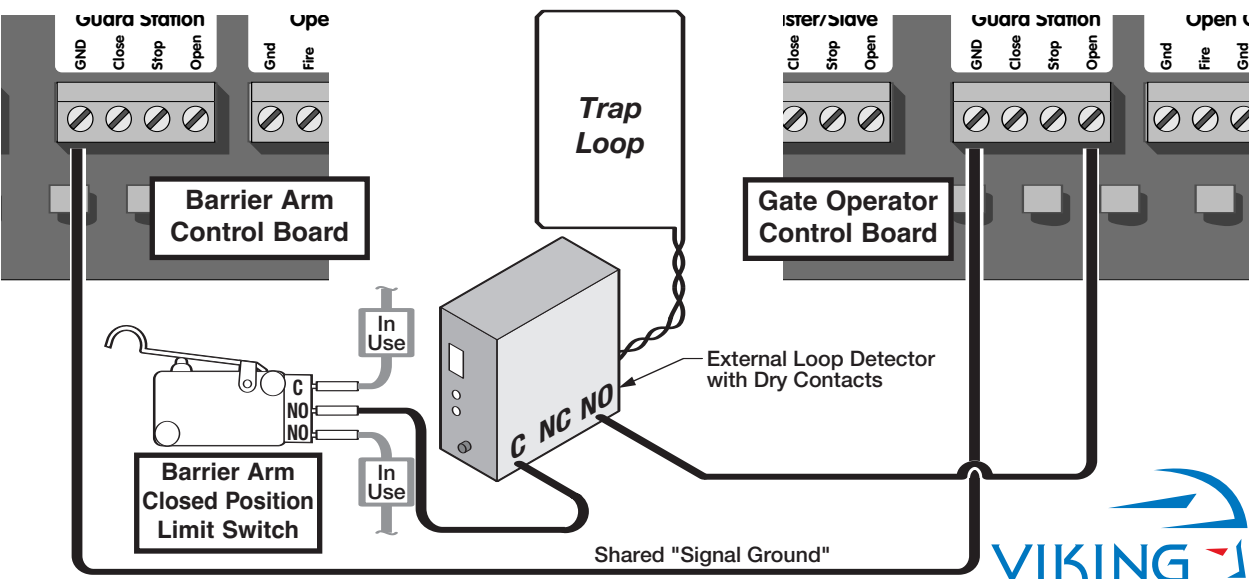

VEHICULAR LOOP DETECTOR INSTALLATION

Entry Side Configuration

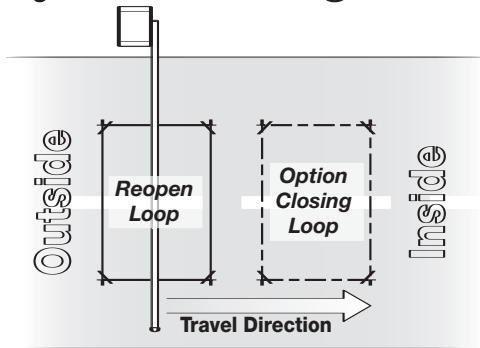

Exit Side Configuration

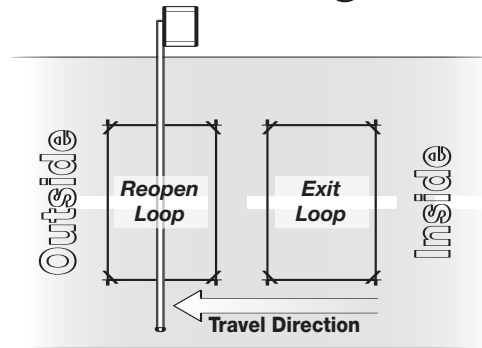

Typical Wiring Diagram

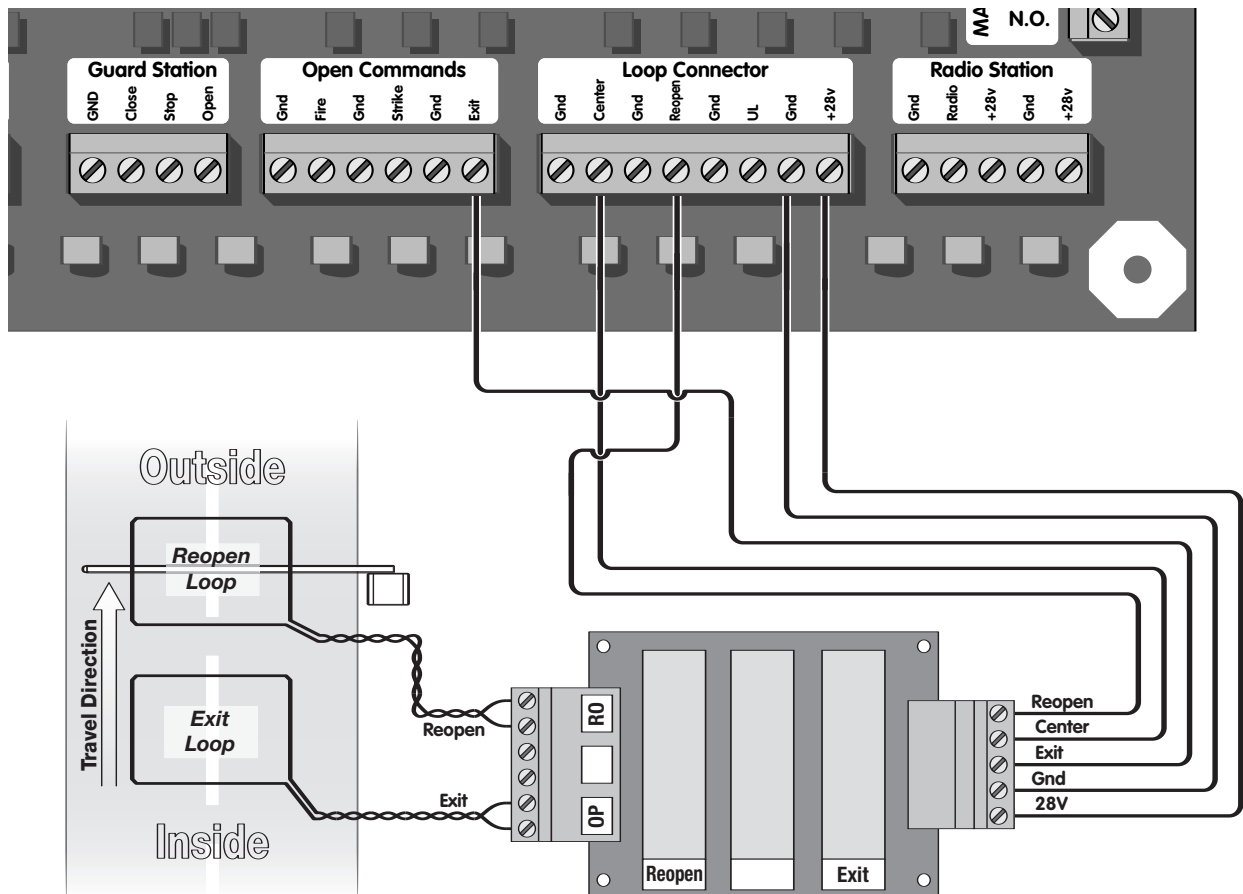

Note: Not all loops may be necessary for every installation. Check local regulations and accepted best-practice design requirements.



VEHICULAR LOOP DETECTOR INSTALLATION

WARNING – Consult the installation instructions from the loop detector manufacturer. The following statements are provided as a guide but different requirements may be required by the vehicular loop detector manufacturer.

Guidelines for Vehicular Loop Detector Installation

1. Prevent sharp corners in the geometry of the loop sensor.
2. Install the appropriate number of turns for your loop geometry based on the loop perimeter. Use Table C (below) as a guide.
3. Use XLP (cross-linked-polyethylene) type of wire. This wire reduces the effects of moisture and other environmental events in altering the functionality of the vehicular loop detector.
4. Twist the lead wire at least 6 turns per foot.
5. Use BACKER-ROD to minimize damage to the loop detector wire prior to using the sealant.
6. Place the loop detector wire and adjust the sensitivity of the vehicular loop detector unit in a way to minimize the effects of the gate over the loop detector wire.

IMPORTANT – Some of the following parameters may affect the proper functionality of the vehicular loop detector (consult the installation manual and the manufacturer of the vehicular loop detector).

- Gate size,
- Number of turns in the loop sensor wire;
- Distance from the loop sensor wire to the gate either at the open or close position.

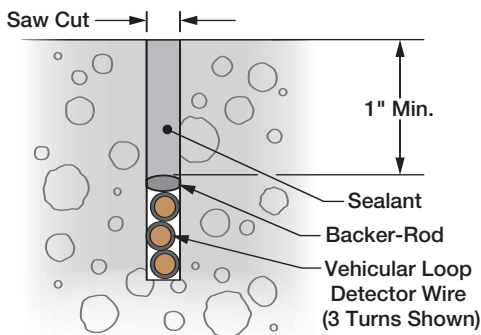
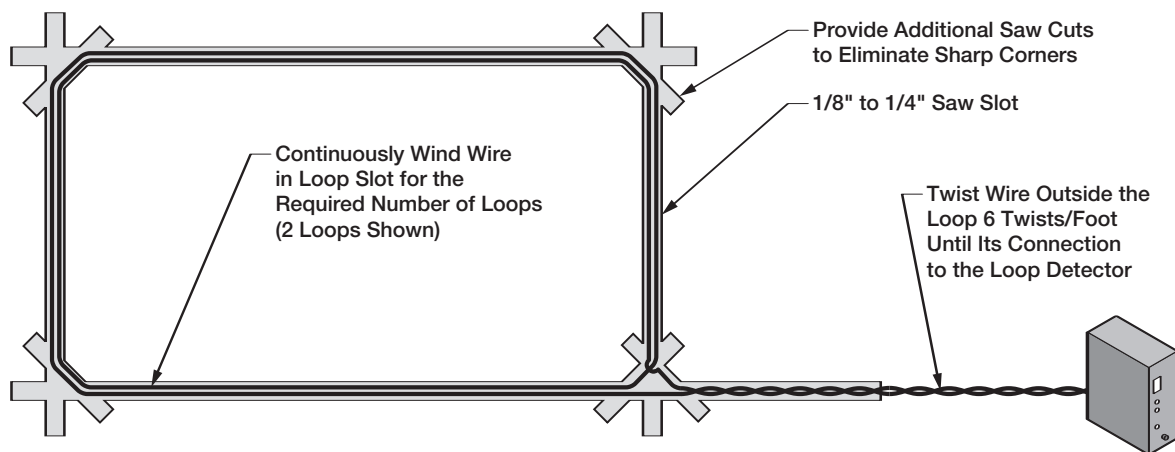
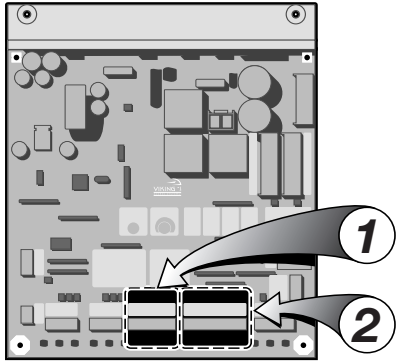

Table C – Recommended Number of Turns

Perimeter in Feet	Number of Turns
10	5
20	4
30-40	3
50-100	2



ACCESSORY CONNECTIONS



Connection Locations
(Single Unit Board shown)

Vehicle loop detectors must be installed to decrease the possibility of vehicle entrapment on the gate (see page 20).

The SECONDARY ENTRAPMENT PROTECTION like the edge sensor and the photoelectric beam MUST BE PART OF EVERY SINGLE INSTALLATION to prevent pedestrian or animal entrapment (see pages 6 and 7).

Open Commands

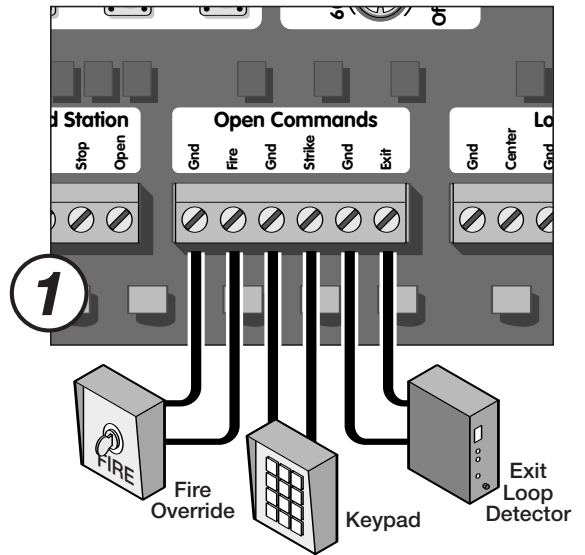

Safety Connections

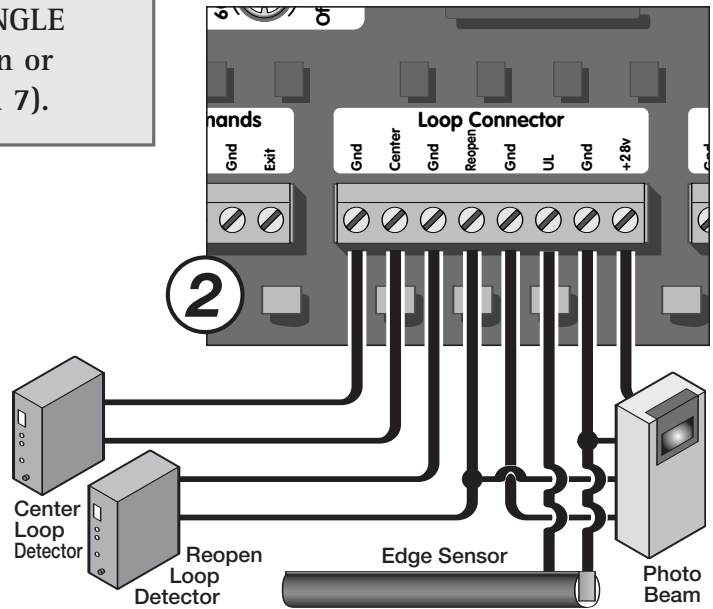

ACCESSORY CONNECTIONS

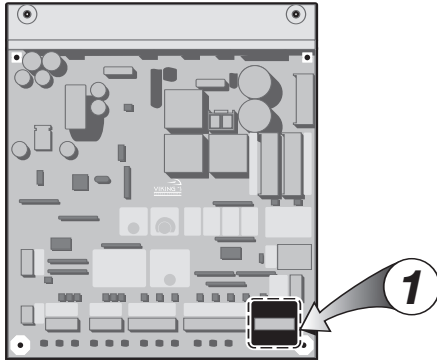

Connection Locations

Note: All controls are normally open.

Radio Receiver

When connecting the Radio Receiver carefully verify the proper connections. The maximum voltage that the control board provides for external accessories is the maximum voltage of the battery, which is about 28 volts. In the event of an electrical short the board will protect itself by shutting down and will remain shut down until the short is corrected.

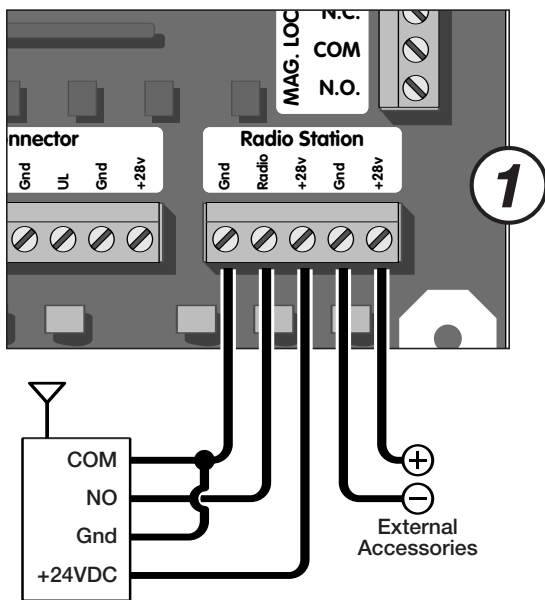

The control board provides two modes of operation that a radio receiver can control the gate:

Open-Stop-Close

1. By having the radio receiver connected as illustrated and with the Hold Open Timer OFF (see below):

Every command of the radio transmitter will control the gate as follow:

- a) First command opens the gate,
- b) Second command stops the gate and
- c) Third command closes the gate
- d) Any subsequent commands will continue in the same order to control the gate.

This type of configuration is not recommended for a commercial installations.

Open Only

2. By having the radio receiver connected as illustrated and with the Hold Open Timer ON (see below):

Each command of the radio transmitter is ALWAYS AN OPEN COMMAND to the gate.

ACCESSORY CONNECTIONS

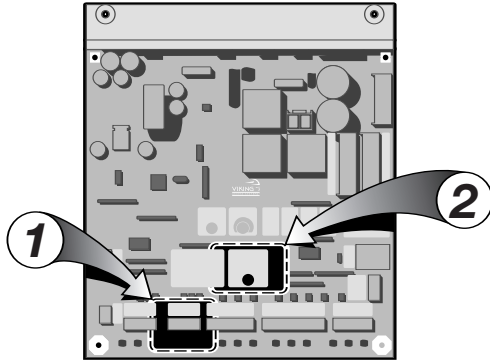

Connection Locations

Guard Station

The guard station provides control of the gate operator to open, stop and close the gate.

All three switches must be Normally Open type of switch, and can share the same common (ground).

Place the control switch box within sight of the gate, away from moving parts of the gate and out of reach of children.

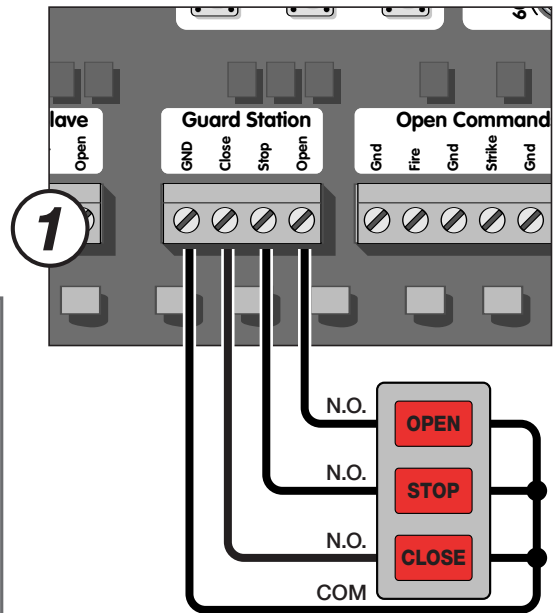

Hold Open Timer

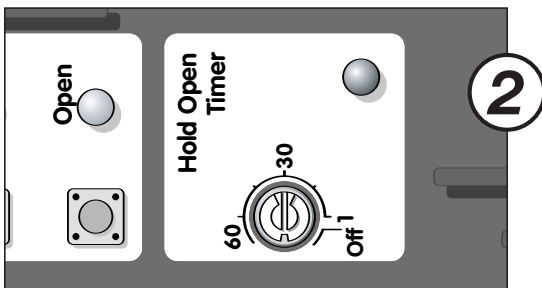

The Hold Open Timer function holds the gate at the open position for a predetermined amount of time, prior to closing automatically.

Set the Timer to the desired time, from 1 to 60 seconds.

If this feature is not needed, turn the Trim Pot clockwise to the “off” position.

Note: The Hold Open Timer affects the “radio receiver command” and the sequence of operation for the gate.



SPECIAL FEATURES

Auto-Open Feature

The Auto-Open feature in Viking Gate Operators enables the following functionality in the event of power failure:

- a) Open the gate in case of power failure (120 or 220 VAC).
- b) Keep the gate at the open position as long as there is no power.
- c) Resume to normal operation when the power has been restored.

The Auto-Open feature allows proper operation while opening in case of power failure for the following devices:

- All accessories,
- All safety devices,
- All entrapment protections.

The only operation that can not be executed while opening in case of power failure is to CLOSE the gate.

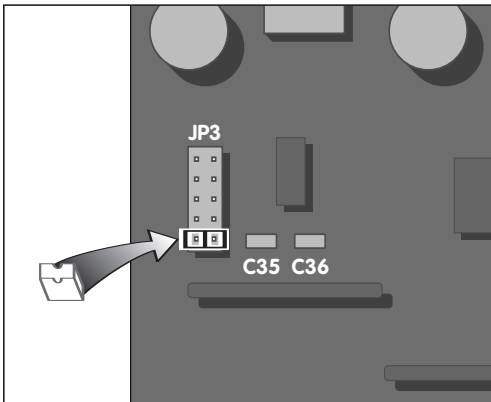

To enable the Auto-Open feature : Use the “jumper” provided and place it on the pin-header of JP3, on the terminals close to C35 as the illustration indicates.

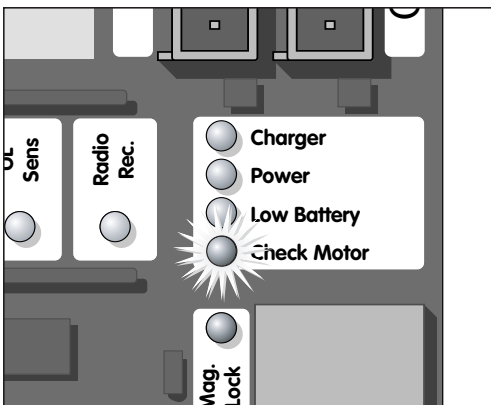

Once you put the “jumper” on the control board the “Check Motor” light will come on indicating that the Auto-Open feature has been enabled.

SPECIAL FEATURES

Intelligent Obstruction Sensor (Primary Entrapment Protection)

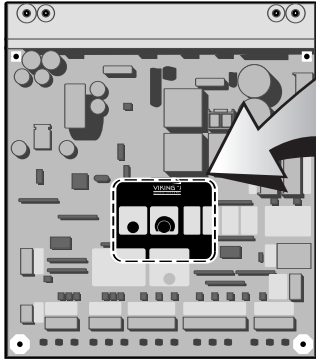

Trim Pot Location
(Single Unit Board shown)

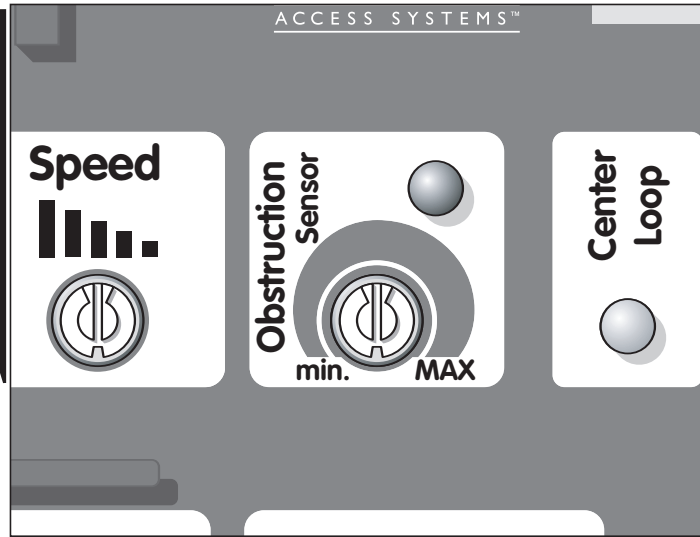

Turning the Trim Pot clockwise increases the sensitivity.

Turning the Trim Pot counter-clockwise decreases the sensitivity.

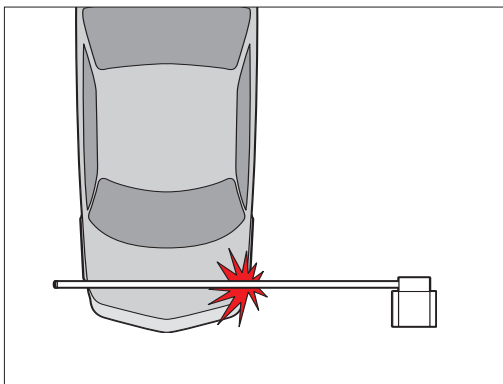

The Obstruction Sensor detects obstructions in the path of the traveling gate. The Trim Pot for the Obstruction Sensor adjusts the sensitivity level that triggers the Sensor.

When the Obstruction Sensor detects an obstruction it will:

1. Stop the gate's movement and reverse it momentarily.
2. Bring the gate to a resting position.
3. Disable the Hold Open Timer feature until the Gate Operator receives a new command.

If another obstruction is detected before the gate reaches either limit it will:

1. Stop the gate's movement.
2. Bring the gate to a resting position.
3. Disable the Gate Operator.

UL325 standard requires an audio alarm to go off after two consecutive entrapment events sensed by the Inherent Entrapment Protection of the Gate Operator.

The audio alarm will sound for a period of 5 minutes or until the "Stop" Button is pressed (see page 8 for remote installation of a "Stop" Button).



OPTIONAL SOLAR PANEL INSTALLATION

For Viking Vehicular Gate Operators

STEP 1

Use a 24V solar panel or two solar panels of 12V in series with a total capacity of 80 Watts..

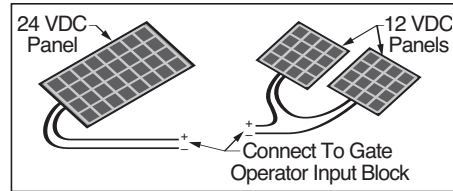

STEP 2

Connect the solar panel cables to the power harness as shown. Make sure you cut the wires coming from the toroidal transformer.

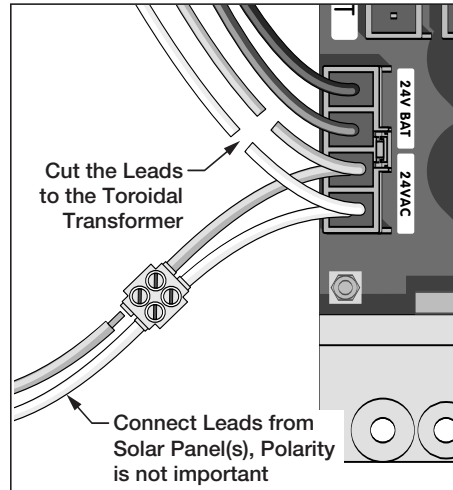

STEP 3

Replace the existing batteries with a battery pack of 33Ahr or greater.

STEP 4

Refer to the maps provided to get an idea about the number of cycles the gate will be operated per day. This figure is for a single gate operator with just:

- One Radio receiver,
- One low voltage low current loop detector and
- One low voltage, low current photo cell

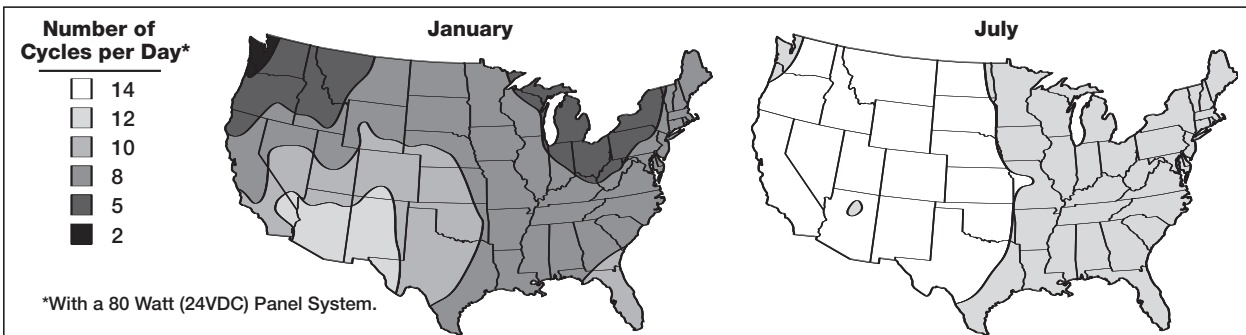
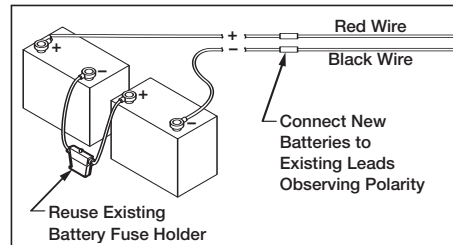

NOTE –

- Remember that the sun is your only source of energy.
- The greater capacity of the batteries, the longer the system will operate on cloudy days.
- If more specific information is needed, please consult with Viking Access Systems. For more information regarding solar energy refer to <http://www.nrel.gov>.



OPTIONAL LIGHTING

Lighting can be added to the aluminum Barrier Arm. Viking part # VA-B12ALK

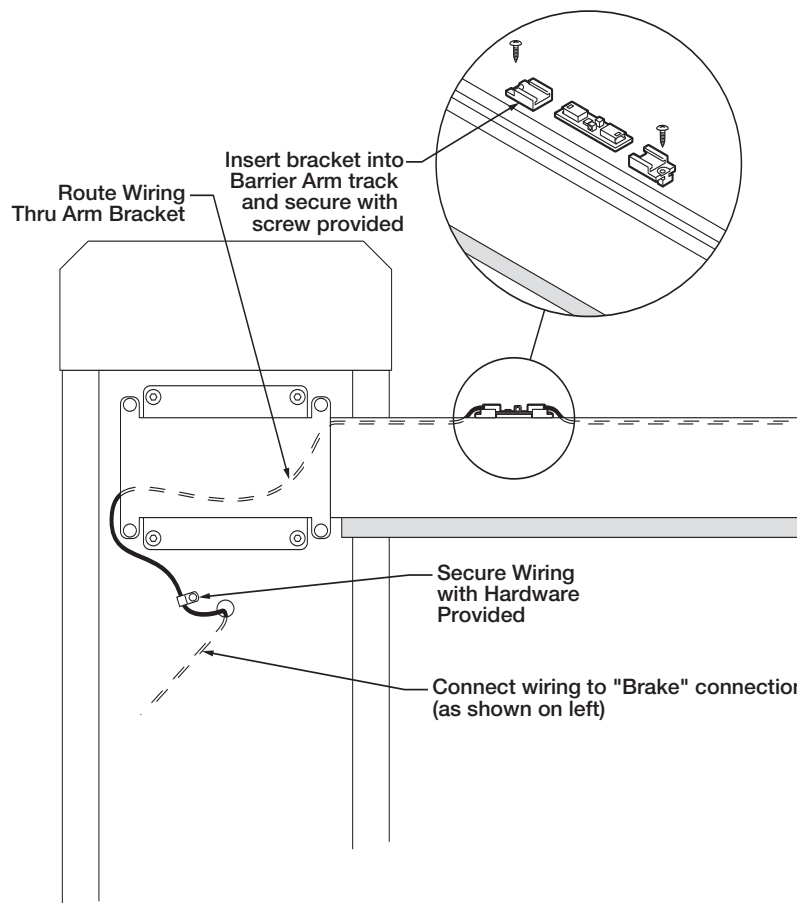
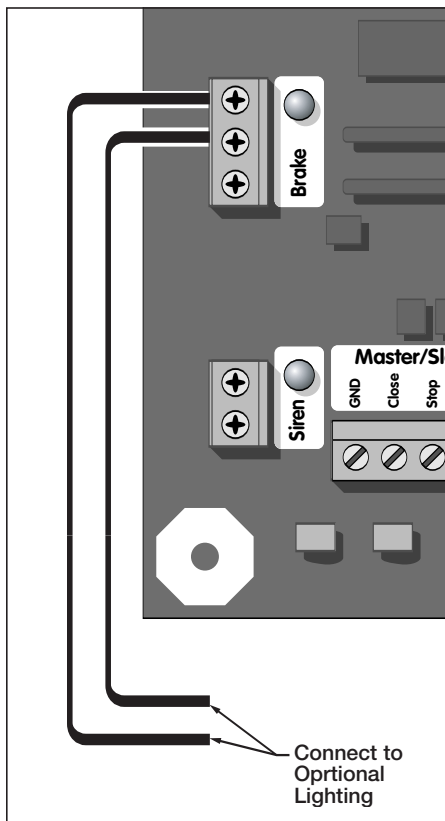
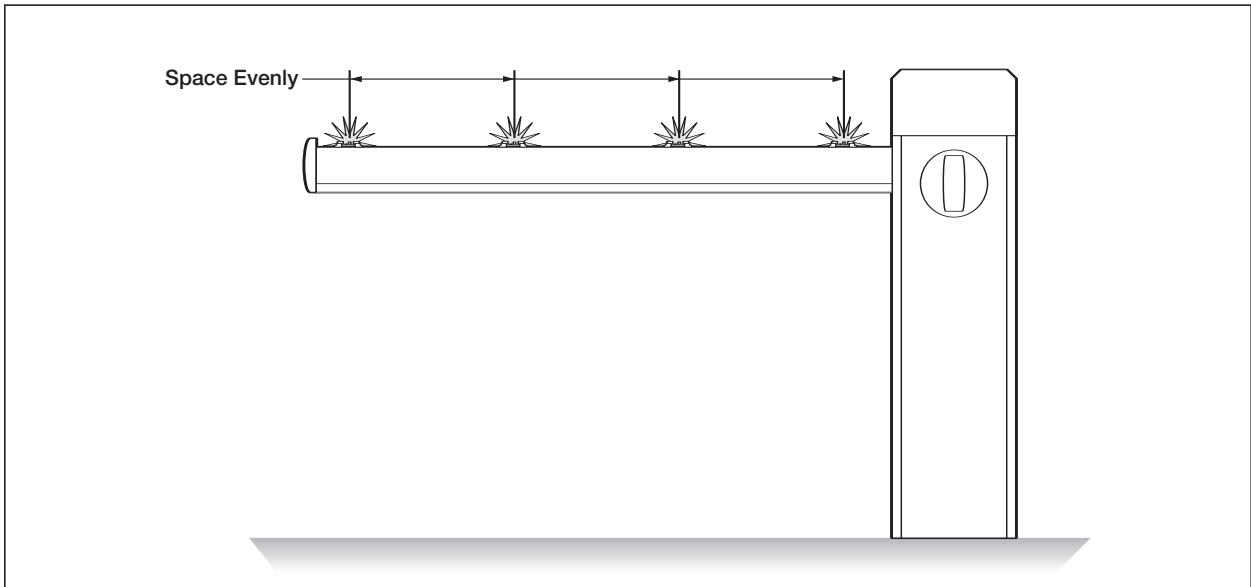

OPTIONAL VIKING BLUE INSTALLATION

WARNING – Connecting the plug backwards can result in damage to the Control Board and will render the Viking-Blue Module useless.

VikingBlue Wireless Master/Slave

1. Decide which Operator will be the Master and which will be the Slave.
- 2a. Install the “Master” Viking Blue Module on the Master Control Board.
- 2b. Install the “Slave” Viking Blue Module on the Slave Control Board.

Use care in connecting the plug to the Control Board. The pins are small and easily bent. Match the white dot on the plug to the white dot on the control board (near the JP2 legend as depicted).

3. Install the Jumper (near the JP3 legend depicted). Viking-Blue requires this jumper to operate as a Master/Slave device. The “Low Battery” LED will turn ON, indicating the Control Board is ready for use with the Viking-Blue Module.
4. Attach the Viking-Blue Module to the Operator. For better communication and performance follow these guidelines:
 - The Module must be under the Operator Cover.
 - The Modules must be facing each other as much as possible.

The Light on the Viking-Blue module will turn green upon connection between the other Module. Be sure to test your Master/Slave communication.

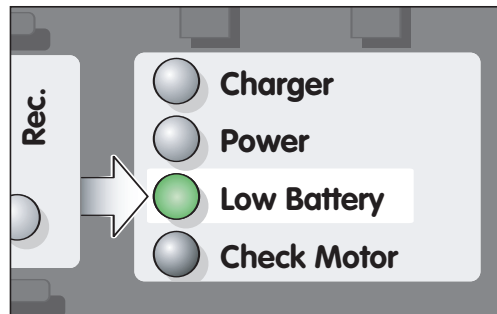
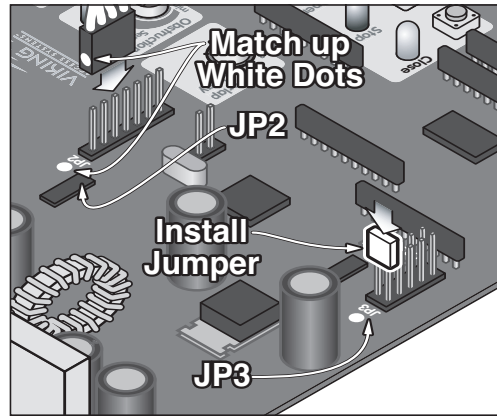

VikingBlue Wireless Diagnostics

1. Insert CD into host computer
2. Install MS ActiveSync (check your computer, it may already be installed to communicate with a PDA or smart phone.
3. Install Viking Blue software
Select Install Viking-Blue for PC (to have the computer to communicate with the Operator)
Select Install Viking-Blue for PDA (to have the PDA to communicate with the Operator)

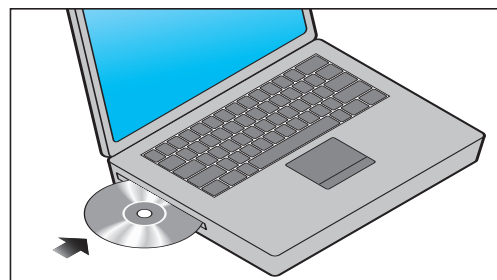

OPTIONAL VIKING BLUE INSTALLATION

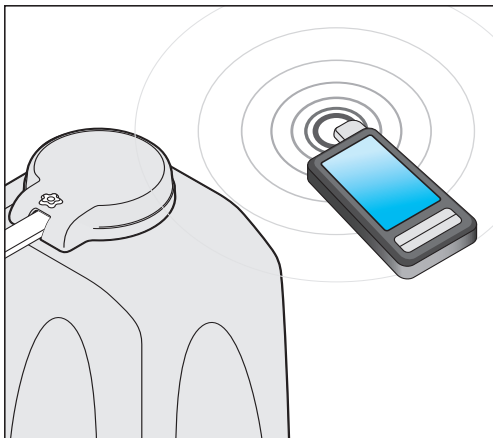
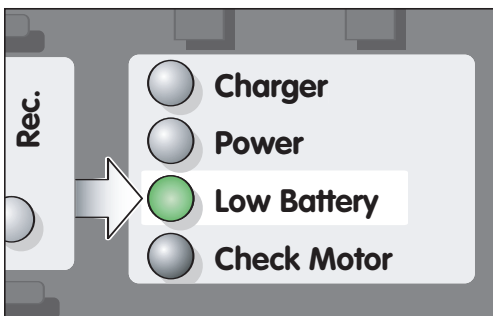
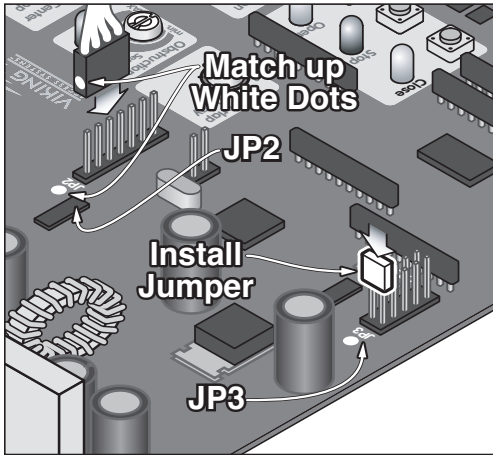

WARNING: If this PDA is a new device, turn off all options when syncing with the computer. For either installation, follow the steps in the user manual.

4. Plug the Viking Blue Module into the Viking Gate Operator Control Board.

WARNING: Connecting the plug backwards can result in damage to the Control Board and will render the Viking Blue Module useless.

Use care in connecting the plug to the Control Board. The pins are small and easily bent.

Match the white dot on the plug to the white dot on the control board (near the JP2 legend as depicted).

5. Install the Jumper (near the JP3 legend depicted). Viking-Blue requires this jumper to operate. The “Low Battery” LED will turn ON, indicating the Control Board is ready for use with the Viking-Blue Module.

6. Open Viking Blue software on the chosen device.

If you are using the computer:

- Hold the computer near the Gate Operator.
- Run the application by clicking the icon on the desktop.
- Select “Setting” in the top right of the screen.

If you are using a PDA:

- Hold the PDA near the Gate Operator.
- Select “Start” and “Programs”.
- Click the Viking-Blue Application.
- Select “Connection” on the toolbar.
- Click “Search” (looking for available Viking devices).
- Select the Operator you want to communicate with.
- Click “Connect” to start communication.

The Light on the Viking-Blue module will turn green upon connection to the Computer or PDA.

Follow the steps in the user manual.



OPTIONAL ARTICULATED ARM *Viking Part No. VA-B12AAK*

For Viking B-12 Barrier Arm Operator

STEP 1

Determine Primary and Secondary Arm lengths based on obstructions and desired open height. Cut Arm squarely and clean up any rough edges.

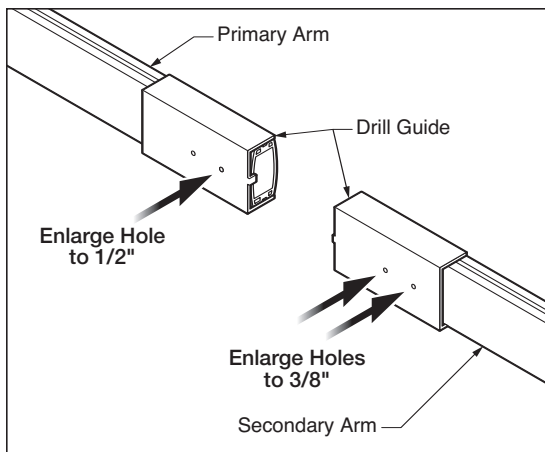
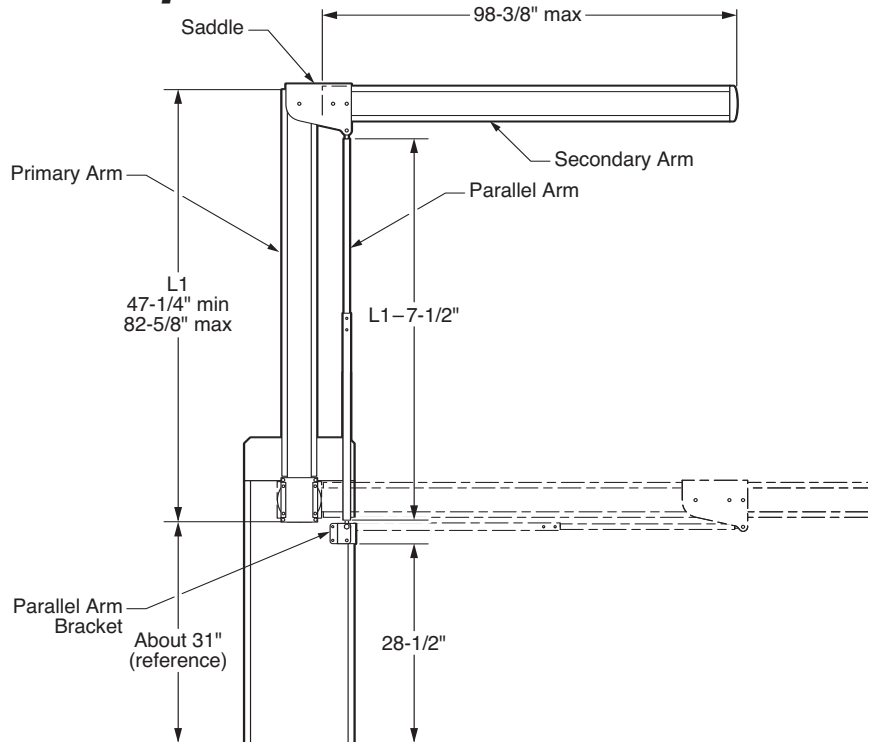

STEP 2

Drill 1/8" pilot holes in Arms using Drill Guide at positions shown. Enlarge the one hole in the Primary Arm to 1/2". Enlarge the two holes in the Secondary Arm to 3/8"

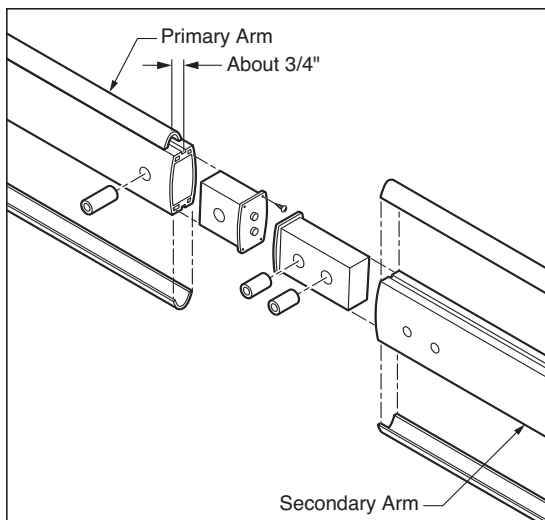

STEP 3

Insert Primary Arm Cap and secure with short sheetmetal screws. Insert longer (1.6" long) Threaded Coupling into hole drilled in Step 2. Insert shorter (1.3" long) Threaded Couplings into Secondary Arm Cap. Insert Cap into Secondary Arm secure with short sheetmetal screws. Reinstall the Arm Edge Protectors, leaving a gap on the top of the Primary Arm Edge Protector as shown.

TROUBLESHOOTING

Arm does not run – Motor Sensor indicator comes ON

Check all motor connections to be fully engaged. Refer to page 14.

Ensure that the motor connections are:
a) Properly connected;
b) Tight enough and;
c) Match color code.
Refer to page 13.

Check that all motor cable connections, junctions and extensions are properly connected and color-coded. Refer to page 13.

Check the 15 Amp fuse in the control board

Arm does not run – Motor Sensor indicator is OFF

Check all motor connections to be fully engaged. Refer to 14.

Check that the stop command is not active. Refer to page 23.

Check that the unit is not in release mode. Refer to page 7.

Check that the UL command (edge sensor) is not active. Refer to page 7.

Check that the vehicular loop detectors are working properly. Refer to page 19 and 20.

Check that the radio command is not active. Refer to page 22.

Ensure that you external accessories are working properly.

Check the 4 Amps fuse in the control board

Ensure that you power cables are adequate in voltage and properly connected. Refer to page 13.

Arm does not run – Power failure

Check the 15 Amp battery fuse. Refer to page 16.

Check the battery connections and cables.

Check the voltage of the battery.

Arm runs, stops and reverse momentarily – Obstruction sensor ON and audio alarm OFF

Ensure that the arm path is clear of obstructions.

Check for proper functionality and lubrication of the arm and hardware (hinges and the like).

Adjust the trim pot of the obstruction sensor. Refer to page 25.



TROUBLESHOOTING

Arm does not open or close

Check all motor connections to be fully engaged. Refer to page 14.

Check that the stop command is not active. Refer to page 23.

Check that the UL command (edge sensor) is not active. Refer to page 7.

Check that the vehicular loop detectors are working properly. Refer to page 19 and 20.

Check that the radio command is not active. Refer to page 22.

Ensure that you external accessories are working properly

Automatic close does not function

Check that the trim pot of the hold open timer is set to the proper time delay. Refer to page 23.

Note: Hold open timer closes the gate automatically once the gate reaches the limit open. The time delay to close is set by the trim pot. To turn this system off turn the trim pot all the way clockwise

Arm opens in the opposite desired direction

Verify your motor cable is connected to the proper connector. Refer to page 14 and 18.

Check that all motor cable connections, junctions and extensions are properly connected and color-coded.

Arm opens. Closes or stops on its own

Check that your external devices are working properly

Check that your wires from your accessories are:
a) Not shorting together
b) Not shorting a power line
c) Not shorting to metal or earth ground.

Green 'Charger' LED not illuminated

Check power supply

Check that there is AC power.
Check Fuse on EMI board.
Check for proper power selection (120/220 VAC) on EMI board.
Check power harness plug on control board.

our continuous commitment to excellence

Viking Access Systems is continuously working hard to identify and design products that will appeal to the industry and its needs. As technology continues to advance, we have developed a completely efficient and intelligent line of gate operators to meet the changing demands. These machines offer; full UL325 and UL991 compliance, soft-start and soft-stop, intelligent obstruction sensors, continuous operation (100% duty cycle) and extreme power efficiency. Innovative features include; adaptive and self-learning algorithms, redundancy design in both hardware and software to ensure operation and functionality, protection from lightning, short circuit and power surges, and our exclusive helical gearing offering the highest efficiency rating in the industry. Our entire product line is continually modified and improved based on the latest technology and our customer's valuable feedback. The results are products that offer accuracy, efficiency, reliability and performance, all in sleek, high-tech designs.

We pledge to continue establishing ourselves as the leader in high quality, innovative gate operators by developing "Next Level" technology. We are committed to providing safety and convenience with innovative solutions for every security gate need.



VIKING ACCESS SYSTEMS™

standard features

and operator specifications

The Viking B-12™ is Raising the Bar in Barrier Gate Operation. This operator offers features such as; an integrated battery backup system, DC operation, flexibility of installation, and surge protection. It is capable of handling arms up to 16 feet long with speeds from 2 to 3 seconds. The spacious chassis allows easy installation and service access. It is available with 12' or 16' aluminum arm or 14' wooden arm

- Synchronizes with gate operators for access control
- Optional illumination kit available for arm assembly
- Easy access to control board and electronics
- Simple limit switch adjustment and positive stop to assure 100% reliability
- Standard Auto Open feature
- VikingBlue™ compatible
- Powder coated galvanized steel cabinet with plenty of room for accessories
- Plug-in loop rack included
- Keyed release
- High efficiency gearhead motor cycles arms up to 16' in 2 seconds in high traffic applications
- Large footprint for conduit installation
- Battery backup for 400+ cycles of operation in case of power failure



Viking Access Systems
Phone 800.908.0884 Fax 949.753.1640
631 Wald Irvine, CA 92618

www.vikingaccess.com