



# Automatic Vehicle Identification

---

*Identity Flex* Installation Manual  
900 MHz Transceiver

**sirit**  
*IDentifying solutions*

# Notices

**Sirit Corp.**, 33 City Centre Drive, Suite 250 Mississauga, Ontario L5B 2N5

Information contained within this manual is subject to change without notice. No part of this manual may be reproduced or transmitted in any form or by any means, electronic or mechanical, including photocopying and recording, for any purpose without the express written permission of *Sirit Corp.* (SIRIT). © 2001 Markham, ON, *Sirit Corp.* All rights reserved.

**Trademarks:** Product names mentioned in this manual may be trademarks, and they are used for identification only.

Preliminary Hardware Manual  
 Part Number: IDFLEX-MAN-Version 2.1  
**Release Date: 1 January, 2003**  
 IDentity Flex Installation Manual.doc



## NOTICE

This equipment has been tested and found to comply with the limits for a Class B digital device, pursuant to part 15 of the FCC Rules. These limits are designed to provide reasonable protection against harmful interference in a residential installation. This equipment generates, uses, and can radiate radio frequency energy and, if not installed and used in accordance with the instructions, may cause harmful interference to radio communications. If this equipment does cause harmful interference to radio or television reception, which can be determined by turning the equipment off and on, the user is encouraged to try to correct the interference by one or more of the following measures:

- Reorient or relocate the receiving antenna.
- Increase the separation between the equipment and receiver.
- Connect the equipment to an outlet or circuit different to that which the receiver is connected.
- Consult SIRIT.

## SITE LICENCE – CUSTOMER DISCLAIMER

Customer (end user) acknowledges that a site license is required for each *IDentity Flex* system location. It is the customer's responsibility to file for the site license and submit the appropriate filing payment. SIRIT can assist with the completion of the forms. United States filings require completion and submission of FCC Form 601 main with schedule D and H. Canadian filings require completion and submission of Industry Canada Forms IC2365BB and IC2430BB.



## NOTICE

For PERMANENTLY CONNECTED EQUIPMENT, a readily accessible disconnect device shall be incorporated into the fixed wirina.



## NOTICE

For PLUGGABLE EQUIPMENT, the socket/outlet shall be installed near the equipment and shall be easily accessible



## NOTICE

Note: To maintain FCC compliance, the IDentity Flex reader must be used with the power supply that was supplied with the reader.



## TRANSPONDER NOTICE

**WARNING!** Danger of explosion if battery is incorrectly replaced. Replace only with the same or equivalent type recommended by the manufacturer. Dispose of used batteries according to the manufacturer's instructions.

# Contents

**NOTICES ..... II**

**CONTENTS..... III**

**1. IDENTITY FLEX SYSTEM OVERVIEW..... 1**

**System Description .....1**

    Summary ..... 1

    Operation .....2

**Components.....3**

    Identity Flex Transponder Family.....3

    Identity Flex Reader.....5

    Identity Flex Remote Antenna .....6

**2. SITE PLANNING ..... 9**

**Pre-Installation Questionnaire .....9**

**Lane Logic Considerations.....10**

    Parking Access Systems .....10

    Gated Access Systems .....12

    Multiple Reader Installations .....15

**Remote Antenna Mounting .....15**

    Remote Antenna Mounting Options .....15

**Equipment Placement and Cable Routing.....16**

    Reader Location.....16

    Remote Antenna Cable and Conduit Selection .....17

    Remote Antenna Cable Connectors.....18

    AC Power Connections .....19

**List of Materials.....19**

    Hardware Installation Tools.....19

    Interface / Diagnostic Tools.....19

**3. INSTALLATION..... 20**

**Remote Antenna Installation.....20**

**Reader Installation.....26**

**Quick Power-On Test.....27**

**Antenna Lead Installation .....27**

**Cable Connector Installation .....28**

    RG-58/U Cable.....28

    Belden 9913 Cable.....28

    Antenna Cable Adapter.....28

**Interface Connections .....34**

System Interfaces ..... 34  
 Internal Wiegand Pull up Circuit ..... 39  
 Identity Flex Reader - Sync Pulse Characteristics ..... 40  
 Multiple Reader Installations ..... 41  
 Discrete I/O Connector J5 ..... 42  
 Opto-Isolated Relay Control Board..... 46  
 Memory Gate Operation..... 47  
 Polling Sequences and Indicator Lights ..... 49

**4. TRANSPONDER USAGE..... 51**

**Metal-Oxide in Windshields ..... 51**  
**Transponder Testing ..... 51**  
**Transponder Mounting..... 52**  
 Identity Flex & S-Flex Transponder ..... 52  
 External Mount Transponder ..... 53  
 Identity Title 21 Tolling Application Transponder ..... 54  
**Conversion Procedure for T21 Transponders..... 55**  
**Adding External Mount Transponders to the Tag List ..... 55**

**5. DIAGNOSTICS & TROUBLESHOOTING ..... 56**

**Diagnostic Features..... 56**  
**Troubleshooting..... 57**  
 Common Problems and Solutions ..... 57

**6. COMPONENTS, ACCESSORIES AND OPTIONS ..... 63**

*Identity Flex* Component Part Numbers ..... 63  
 Options and Accessories ..... 64  
 Opto-Isolated Relay Wiring Guide ..... 65

**7. COMPONENT SPECIFICATIONS..... 71**

**Reader System ..... 71**  
**Antenna ..... 72**  
 Flex Antenna ..... 72  
 Universal Mounting Bracket ..... 72  
**Transponder ..... 72**  
 Identity Flex and S-Flex Transponder..... 72  
 External License Plate Transponder ..... 73

**8. REFERENCE ..... 74**

**Glossary ..... 74**  
**List of Figures ..... 75**

---

<b>List of Tables</b> .....	<b>75</b>
<b>Index</b> .....	<b>76</b>

# 1. *IDentity Flex* System Overview

## System Description

### SUMMARY

SIRIT's *IDentity Flex* Automatic Vehicle Identification (AVI) system is a stand-alone Radio Frequency Identification (RFID) system which communicates with SIRIT's *IDentity Flex* family of transponders and California Transportation System Title 21 compliant transponders. The *IDentity Flex* system provides positive identification of vehicles equipped with these transponders to permit hands-free access control to parking and gated communities as well as for airport, truck fleet monitoring and highway tolling applications.

The *IDentity Flex* Reader System is enclosed in a weather-resistant enclosure and comprises a radio frequency (RF) transceiver (the reader) and a universal input voltage power supply. Each reader system is capable of servicing four separate transponder-reading locations, each equipped with transmit/receive antennas.

Each reading location can be serviced by two input (detection loops, light curtains) and two output (gate, signal light) devices connected to the reader by appropriate shielded cable. Each of the remote antennas communicates with the reader system through two 50-Ohm coaxial cables.

Multiple readers can be networked to provide coverage of any number of lanes at a given site. The reader system may be configured for customized operation by a combination of externally accessible hardware jumpers and menu-driven software settings via a dedicated RS-232 maintenance communication port.

#### *IDentity Flex*

- ✓ Windshield mounted transponder.
- ✓ Read ranges up to 25 feet.
- ✓ Unique security feature available that deactivates transponder once removed from windshield.
- ✓ Each *IDentity Flex* reader supports up to 4 transponder read points.
- ✓ 2 inputs, 2 outputs at each read location for activation and gate/light control.

The *IDentity Flex* system is capable of communicating transponder transaction activity to variety of established back-end host systems including ASCOM, WPS and Safehouse via. RS 232, RS 485 and Wiegand interfaces, as well as simply reporting transponder identification information.

The *IDentity Flex* Reader can in many situations replace the function of the lane controller as it has discrete outputs on board that can be used for gate control or other lane control functions. In addition, the *IDentity Flex* Reader software contains a translation table that can be used for transponder identification and validation. As an example, if at some future point you wanted to add other *IDentity Flex* transponder patrons from some other installation into your system it can be done simply and economically. This would be both convenient and cost efficient, as patrons would not be required to carry multiple access devices.

## OPERATION

The *IDentity Flex* Automatic Vehicle Identification system is part of an electronic access system and provides the ability to automatically identify a vehicle, validate its movement and communicate this information to a lane controller or centralized management computer.

The SIRIT *IDentity Flex* system features state-of-the-art electronics, a specially designed remote antenna operating at 916.25 MHz and true versatility in configuration options.

While the *IDentity Flex* system may be configured in many ways and no two installations may be identical, there is a certain sequence of events in operation.

The transponder, or radio frequency tag, is placed on the inside of the vehicle windshield, (or on the vehicle's license plate with a special external tag). When a

vehicle passes over a

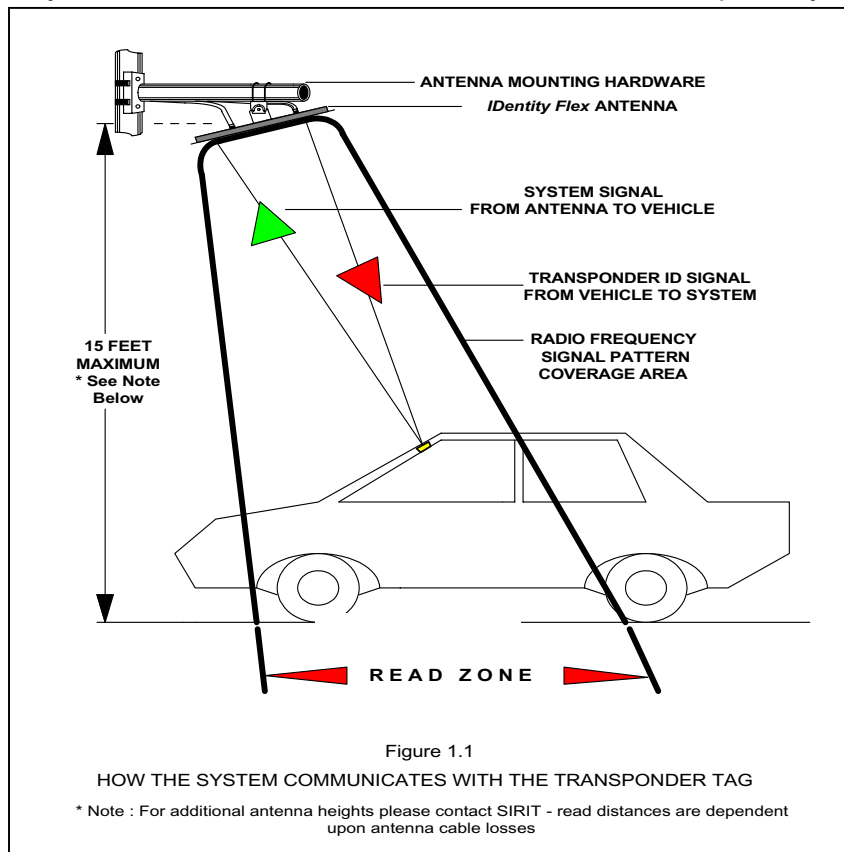

Figure 1.1 – System Operation

detector loop at an entrance or exit, the *IDentity Flex* reader is armed and begins to transmit a signal from the antenna in that lane. The vehicle is also now positioned within the radio beam radiating from an overhead or side-mounted antenna and the tag receives the wake-up signal.

The tag then reflects back a signal containing its identification number. The identification signal is received and sent to the host computer for validation and is compared with tag numbers on a master list kept by the host. If the tag number is valid, the host opens the gate, for instance.

The same events take place when a vehicle leaves the controlled-access location and arming and detector loops in the ground may be used as controls. The host computer maintains an event log containing date and time stamps.

## Stand Alone Operation

The *IDentity Flex* reader is capable of servicing four separate antenna locations. Each of the four locations are supported by two independent discrete TTL capable inputs, which may be used for such purposes as vehicle detecting loops or light curtains. Additionally, each location is also supported by two discrete outputs which are jumper configurable for either +5VDC or +12 VDC current limited outputs. These outputs can be used for such purposes as gate vending control or vehicle stop-and-go light control. Utilizing the ID Flex Windows software, the reader can be configured for stand alone operation.

# Components

## ***IDENTITY FLEX TRANSPONDER FAMILY***

The transponders in the *IDentity Flex* family are small reflective devices designed for vehicle identification. Each transponder is a battery-operated backscatter reflective device that communicates the account information stored in an internal data register of 64 bits when “polled” by the reader system. The transponder is idle unless in the presence of an RF wake-up signal from a reader on 916.25 MHz.

The *IDentity Flex* transponder’s wireless link uses comprehensive error detection methods to ensure a 99.995% accuracy rate even under the most adverse environmental conditions. Error detection and correction also ensures information is transferred accurately between the transponder and reader.

The *IDentity Flex* reader system can communicate with either SIRIT’s *IDentity Flex* family of transponders that utilize a Double Phase-Shift Keyed modulation scheme or CALTRANS (Title 21) readable transponders that utilize a frequency-shift keyed up-link modulation scheme.

*IDentity Flex* transponders mounted in vehicles are placed at the top of the front windshield, behind the rear view mirror. The external mount transponder is attached to the front license plate of the vehicle. See the section starting on page 52 for mounting instructions.

## ***IDentity Flex* Transponder**

The *IDentity Flex* transponder is equipped with a replaceable 4-year coin cell battery and a second battery can be added for longer life. The transponder is attached to the windshield by Velcro™ strips. This allows it to be removed from the vehicle or locked in a glove box while not in use. The *IDentity Flex* transponder is pre-programmed at the factory with a dealer code, facility code, ID number and manufactured serial number.

## ***Security-Flex (S-Flex)* Transponder**

The *S-Flex* transponder is equipped with a 4-year non-replaceable battery and is attached to the windshield with adhesive strips. The transponder will be deactivated if it is removed after installation, preventing use in unauthorized vehicles. Deactivated transponders must be returned to SIRIT for reactivation. Like the *IDentity Flex* transponder, the *S-Flex* is pre-programmed at the factory.

## **External Mount Transponder**

An external mount transponder is preferred in truck fleet monitoring applications and on certain vehicles that have high metal-oxide content in their windshields. This transponder is mounted on the front license plate holder. More information on metal-oxide's effect on Radio-Frequency devices such as the *IDentity Flex* transponders can be found on page 51.

External mount transponders can be read by Title 21 systems and, as such, are programmed for use with the *IDentity Flex* system on-site by the dealer. Mounting instructions can be found on page 53.

## ***IDentity Title 21 (Tolling Application)* Transponder**

The *IDentity Title 21 (T21)* transponder can be read by highway toll collection systems that are compliant with the California Department of Transportation's Title 21 open standard. It therefore serves a dual-purpose role in also allowing access to *IDentity Flex* system controlled areas. It is mounted inside the windshield with Velcro™ strips. The Title 21 identification number can be loaded

into the reader look-up table to allow access to facilities utilizing the *IDentity Flex* reader.

## ***IDENTITY FLEX READER***

SIRIT's *IDentity Flex* reader system is a Radio Frequency Identification (RFID) system that communicates with California Transportation System Title 21 compliant transponders and SIRIT's *IDentity Flex* transponder family.

The *IDentity Flex* reader is mounted within a weather-resistant NEMA 4X rated enclosure and is comprised of an RF transceiver and a universal input voltage power supply. Normally the reader and power supply are mounted onto a supplied backplane which is sized for the locking NEMA enclosure and provides a tidy tamperproof installation. A 120 VAC 15 Ampere power source is required and is adequate to operate one transceiver chassis and power supply.

Each reader system is capable of servicing up to four separate transponder-reading locations (read points). Each of the four read points is supported by two independent discrete TTL capable inputs, which may be used for such purposes as vehicle detecting loops or light curtains. Additionally, each transponder reading location is also supported by two discrete outputs which are jumper configurable for either +5VDC or +12VDC current limited outputs, which may be used for such purposes as gate vending control or vehicle stop and go light control. Each of the four read points may be remotely located from the reader by up to 200' of coaxial cable, which connects the reader to the remote antennas.

The reader system may be configured for customized operation by a combination of externally accessible hardware jumpers and menu driven software settings via the dedicated RS-232 maintenance communication port. Instructions for configuring these settings start on page 34. The reader is connected to a laptop computer running an emulation program such as SIRIT's *IDentity Flex* Windows software, **ProComm**™ or Windows® HyperTerminal™ to perform system setups, configurations and maintenance functions. The maintenance port also functions as an input for the purpose of updating the tag translation list.

The *IDentity Flex* system is capable of communicating transponder transaction activity to a variety of established back-end host systems, as well as simply reporting transponder identification to the Host. Additionally, each of the four different transponder reading channels have their own independent Wiegand protocol output for reporting to back-end systems. The *IDentity Flex* reader is compliant with FCC Part 15 and FCC Part 90 rules.

It is important to establish power requirements and location of the *IDentity Flex* reader in conjunction with the Pre-Installation Questionnaire. A guide to establishing the layout of the system begins on page 9. *IDentity Flex* reader installation instructions begin on page 26.

## **IDENTITY FLEX REMOTE ANTENNA**

The *IDentity Flex* remote antenna is an all-weather dual-aperture (transmit and receive) antenna with an LED feature that permits quick lane configuration. The LED feature is described below. The antenna measures 30" x 12" x 2" and comes in a flat gray finish, and can be repainted with non-metallic paint.

The location and angle of the antenna define its read zone and it is essential that it be installed in the correct orientation and location. The antenna comes with the Universal Mounting Bracket (UMB) and hardware. Optional brackets may be ordered so it can be side-mounted on a pole or wall or ceiling-mounted in any arrangement. A description of these brackets can be found in the next section, and installation instructions begin on page 20.

It is important to establish the remote antenna location and mounting method in conjunction with the Pre-Installation Questionnaire. Refer to page 10 for a guide to lane configuration and antenna location.

### **Antenna LED's – Tag Read Indicator**

SIRIT antennas are equipped with an LED indicator which is normally located at the bottom right-hand corner of the antenna. This LED is used as an indicator and test tool for the installer and facility staff. When any SIRIT tag enters the read zone the LED will illuminate. Once the tag has been removed from the antenna field the LED will extinguish.

This feature will assist the installer in setting the desired read pattern and signal strength. In addition, if system problems are encountered (e.g. the gate does not open) this option will help the troubleshooter. If the LED illuminates then the *IDentity Flex* reader has read the tag and the cause of this fault is in the tag list control or back end system. If the LED does not illuminate then there could be a problem with the reader/antenna system, the tag or something that is restricting the read such as metal-oxide in the windshield.

For earlier model Flex systems that require an external LED driver, Sirit can provide a retrofit kit to allow the addition of an external LED indicator which may be located at the antenna or else where in the lane. For installation of this option SIRIT recommends that the installer run a separate wire to each antenna of 2 conductor 18 AWG cable.

### **Remote Antenna Mounting Brackets**

This section is designed to familiarize the dealer with options for mounting the remote antenna that will ensure an acceptable read zone for each installation. The following catalog of mounting brackets will assist the dealer in completing

the Pre-Installation Questionnaire and determining which installation method will be used for each lane.

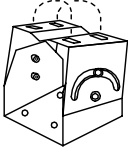
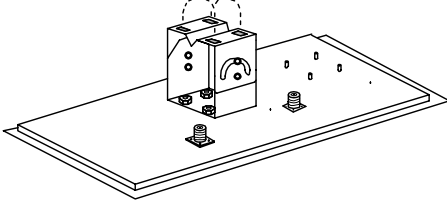
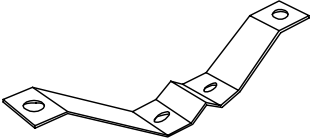
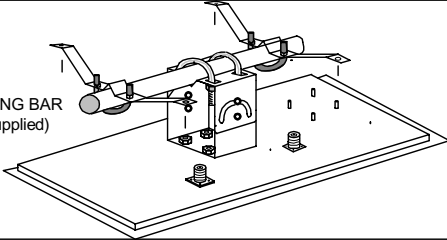
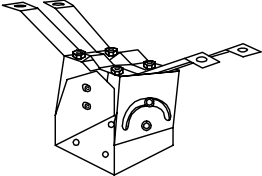
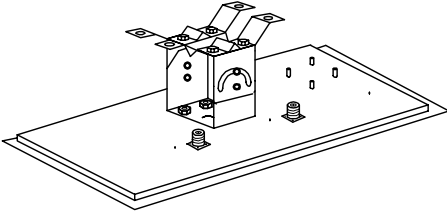
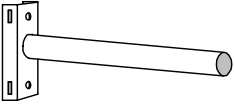
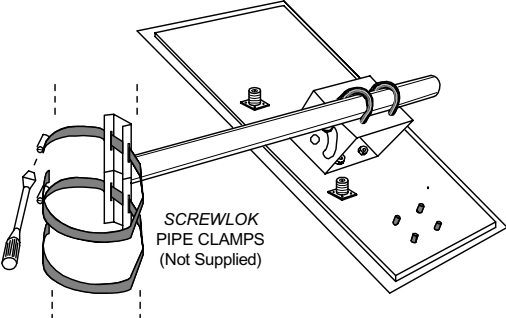
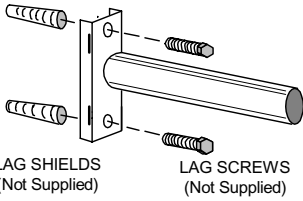
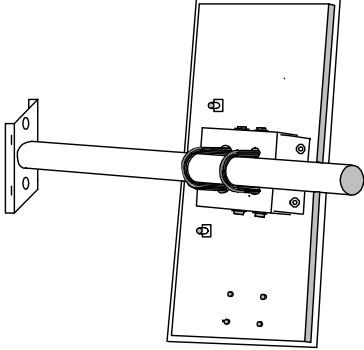
<b>IDentity Flex ANTENNA MOUNTING OPTIONS</b> (See Option Sheet for actual parts that are included)		
		<b>ANTENNA WITH UNIVERSAL MOUNTING BRACKET (AS SOLD)</b>
<b>IDFLEX-ANT-01</b>		
	 <p>MOUNTING BAR (Not Supplied)</p>	<b>UNIVERSAL CEILING MOUNT BRACKET</b>
<b>IDFLEX-ANT-CMB</b>		
		<b>OPTIONAL CEILING MOUNT METHOD</b>
<b>IDFLEX-ANT-CMB+WMB</b>		
	 <p>SCREWLOK PIPE CLAMPS (Not Supplied)</p>	<b>UNIVERSAL POLE / WALL MOUNT BRACKET</b>
<b>IDFLEX-ANT-WMB</b>		
 <p>LAG SHIELDS (Not Supplied)</p> <p>LAG SCREWS (Not Supplied)</p>		<b>OPTIONAL UNIVERSAL POLE / WALL MOUNT BRACKET</b>
<b>IDFLEX-ANT-WMB</b>		

MAN-IDFLEX-FIG7A

Figure 1.2 – IDentity Flex Mounting Options

## Coaxial Cables and Conduit

Communication between the *IDentity Flex* reader and the remote antennas is by means of coaxial cable. There are two cables from each antenna to the reader – one for the transmit signal, one for the receive signal. Conduit diameter must be sufficient to house both cables and any other communication cabling required at the read location. Power cables should not be housed in the same conduit as these cables.

Cable selection is dependent on the distance between the reader and the remote antennas. It is important to establish the cabling requirements in conjunction with the Pre-Installation Questionnaire. See the Site Planning Guide section on cabling starting on page 17.

Below is a summary of important installation tips:

- If the cable run between the reader and the remote antenna is less than 50 feet, use Belden 8240 (RG-58/U) cable.
- If the cable run between the reader and the remote antenna is more than 50 feet (to a maximum of 200 feet) use Belden 9913 cable.
- For Belden 8240 (RG-58/U) cable, installers will need to provide connectors. SIRIT can provide these by quoting part # IDFLEX-CONN-RG-58/U. Each kit contains enough connectors to install one antenna - two (2) Amphenol 82-5375's and two (2) AMP 226600-1's.
- A pre-connectorized cable kit is also available from Sirit, Order PN IDFLEX-CONN RG58/U-60K. Each kit contains 2 – 50' lengths of RG58/U cable with "N" connectors installed and 2 crimp mini-uhf connectors not attached.
- For Belden 9913 cable, installers will need to convert from 9913 to a mini UHF connector at the reader end. SIRIT can provide a cable converter kit as an option by quoting part # IDFLEX-CABLECON. Each kit contains enough connectors for one antenna.
- For Belden 9913 cable, installers will need to provide connectors. SIRIT can provide these by quoting part # IDFLEX-CONN-9913. Each kit contains enough connectors to install one antenna - four (4) Amphenol 82-202-1006 connectors.
- **Installers must use the proper crimping tool to install the above connectors.** You can purchase this item locally (Amphenol CTL-5) or SIRIT can provide this as an option by quoting part # IDFLEX-CRIMP.
- SIRIT recommends that outside connectors be weather-proofed by applying proper weather-proofing tape. First, mastic tape is applied over the dry connector then covered with electrical tape. Tape kits are available from SIRIT by quoting part number IDFLEX-CONN-WKIT.



# 2. Site Planning

## Pre-Installation Questionnaire

The Pre-Installation Questionnaire provided by SIRIT is an essential tool in determining the site layout and equipment needs.

This guide has been designed to assist the planner make decisions about lane configurations. If any questions arise regarding the location of vehicle presence loops, gates and remote antennas, the answers should be in the following section.

If there are questions about cabling and connectors, the Installation Tips sheet on the front of the questionnaire should cover them, and a further description can be found in the section starting on page 17.

### SIRIT Pre-site Assistance

As an added service SIRIT offers pre-site assistance to our resellers. Upon receipt of a purchase order for an *IDentity Flex* System, SIRIT will send a fax or email which:

- 1) Confirms the order;
- 2) Requests transponder facility code and identification information (if transponders have been ordered) and
- 3) Requests completion of our pre-site questionnaire. SIRIT takes pride in assisting our resellers by reviewing and making recommendations on pre-site requirements.

If you have not received your confirmation fax with the above information please contact SIRIT.

# Lane Logic Considerations

The following sections contain guidelines for establishing lane configurations, first for Parking Access, then additional considerations for Gated Access starting on page 12.

## **PARKING ACCESS SYSTEMS**

### **Antenna Mounting – Read Zone**

The Read Zone is a roughly conical space between the antenna and the elliptical area on the ground that the signal illuminates. Once the transponder is in the read zone, it reflects a signal back to the antenna. The shape of the read pattern is dependent on the location of the antenna, its orientation on the mounting bracket and the power output of the reader. The installer should use the following guidelines to ensure that:

- Transponders in adjacent lanes are not read
- Vehicles are not trapped between the read zone and the gate
- Vehicles slow to an appropriate speed (or stop) before the gate opens.

Lane presence inductive loops are typically embedded 8-10 feet from the gate and the read zone should start just past this loop moving towards the gate.

For Parking Access Systems, SIRIT recommends that the antenna pole or overhead antenna be mounted approximately 2 – 3 feet in front of the gate. This will ensure that the antenna read pattern will be at approximately 10 feet from the gate and in close proximity to the presence loop. Once the antenna is aimed (approximately 40° angle from vertical) the antenna pattern will be within this 10-foot range.

Antennas are typically mounted on poles or ceilings at 10 –15 feet in height. Angling the antenna down so that the beam is in the desired location ensures proper reading of tags. The antenna can be physically adjusted and the power settings set in the reader software to obtain the desired results. Setting the power level too high may result in reflection of the beam and the possibility that adjacent lanes will be read. Setting the power level too low may result in no or intermittent tag reads.

The following diagram gives an example of a typical installation. These figures are examples only and should not be utilized as an installation guide. For further assistance, please contact a SIRIT representative.

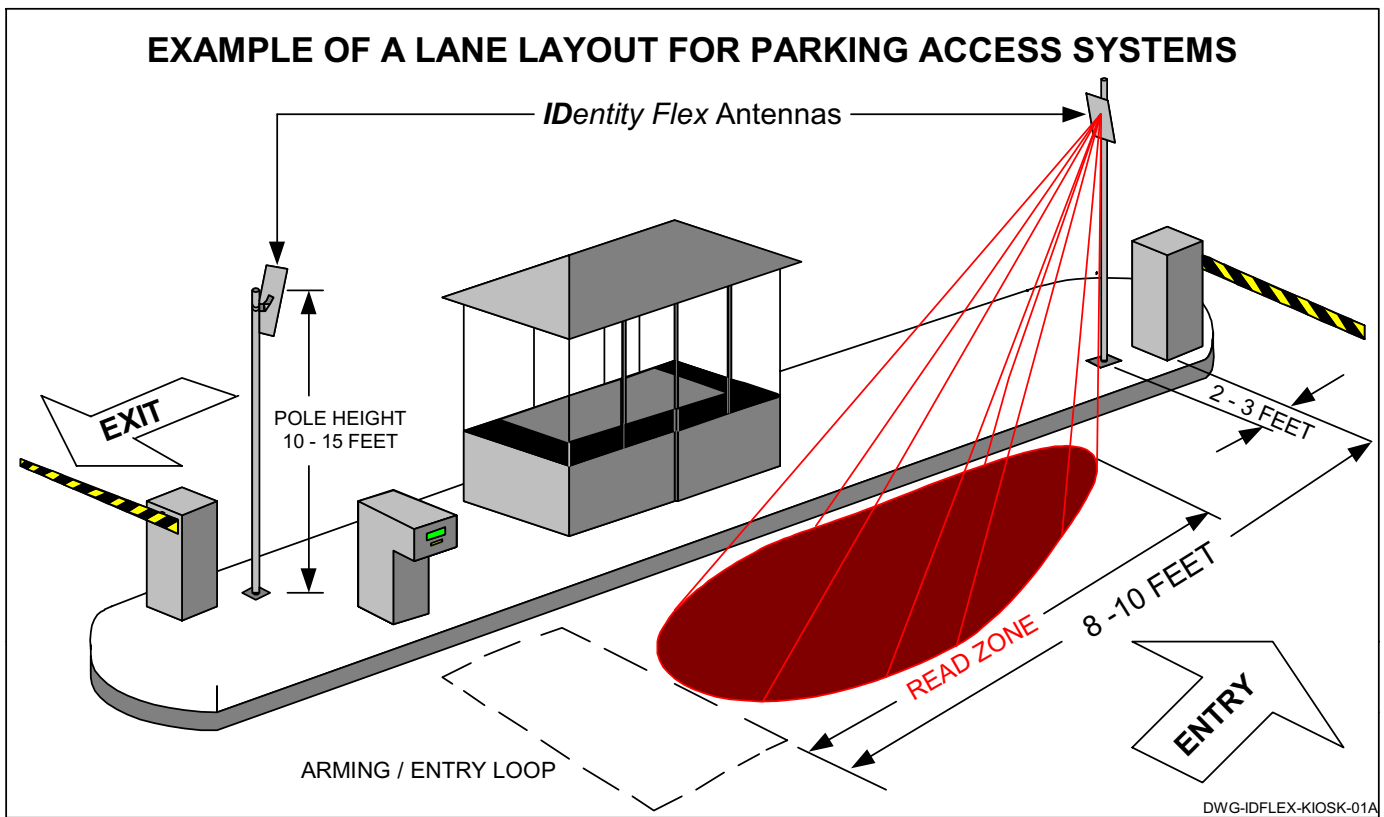

Figure 2.1 – Typical Parking Access Lane Configuration

## Memory Gates

Memory gates are typically used if the SIRIT antenna read zone will be positioned more than 10 feet from the gate or where there is a possibility that a vehicle may get stuck between the presence loop and the gate and not be in the read zone. Memory gates are used to buffer the gate open signal for the second or third car in the lane depending upon how far back the read pattern is. The further away the antenna read range, the more signals the gate will have to buffer. If antennas are too far back in the lane, there is a possibility that a lane logic issue will result, if an invalid vehicle enters the lane along with valid vehicles.

## Internal Buffer Circuit

SIRIT has an internal buffer circuit that can be used only when the *IDentity Flex* reader controls the gate directly. It operates in the same fashion as memory gates as stated above by buffering the gate open signal. The *IDentity Flex* reader must receive a change of state of a gate position signal to clear the buffer or pass the next gate open signal.

## Arming the SIRIT IDentity Flex Antenna

Under certain conditions it is desirable to arm the SIRIT *IDentity Flex* antenna on demand. This can be accomplished by using the dry contact output from the Gate Down position switch, presence loop dry contact output or both. For example the location may have a situation where users remove the *IDentity Flex* transponder from the vehicle and walk past the antenna. If anti-passback is activated then the users' vehicle may be locked in. In this situation it is desirable to only read the transponder when the vehicle is over the presence loop. The presence loop would be used to arm the antenna. Arming the antenna also ensures that there is no risk of unwanted reads if a vehicle comes close to an antenna but is not on the presence loop.

The site may not have memory gates and this means that the AVI signal should not be sent to the host until the gate starts in the Down position. If the AVI signal is sent while the gate is in the Up position it will be lost. At the same time it is desirable to read the transponder while the vehicle is over the presence loop. To accomplish this the dry contacts of the Gate Down position switch and the loop output dry contacts can be connected in series. When both conditions are met, with the vehicle over the loop and the gate arm *starting* to come down, the antenna will be armed and the transponder will be read. In this scenario it is desirable to have the antenna read pattern within 10 feet of the gate (antenna pole mounted at 2-3 feet from the gate). This avoids having the vehicle stuck in the lane due to a lane logic issue.

## GATED ACCESS SYSTEMS

Gated Access systems maybe different from Parking Access as the traffic flow and overall requirements differ. In Parking Access there are revenue control considerations and a requirement to open the gate when the vehicle is close to the gate. This may or may not be the same in Gated Access systems.

Figure 2.2 shows typical Gated Access lane configurations. These figures are examples only and should not be utilized as an installation guide. For further assistance, please contact a SIRIT representative.

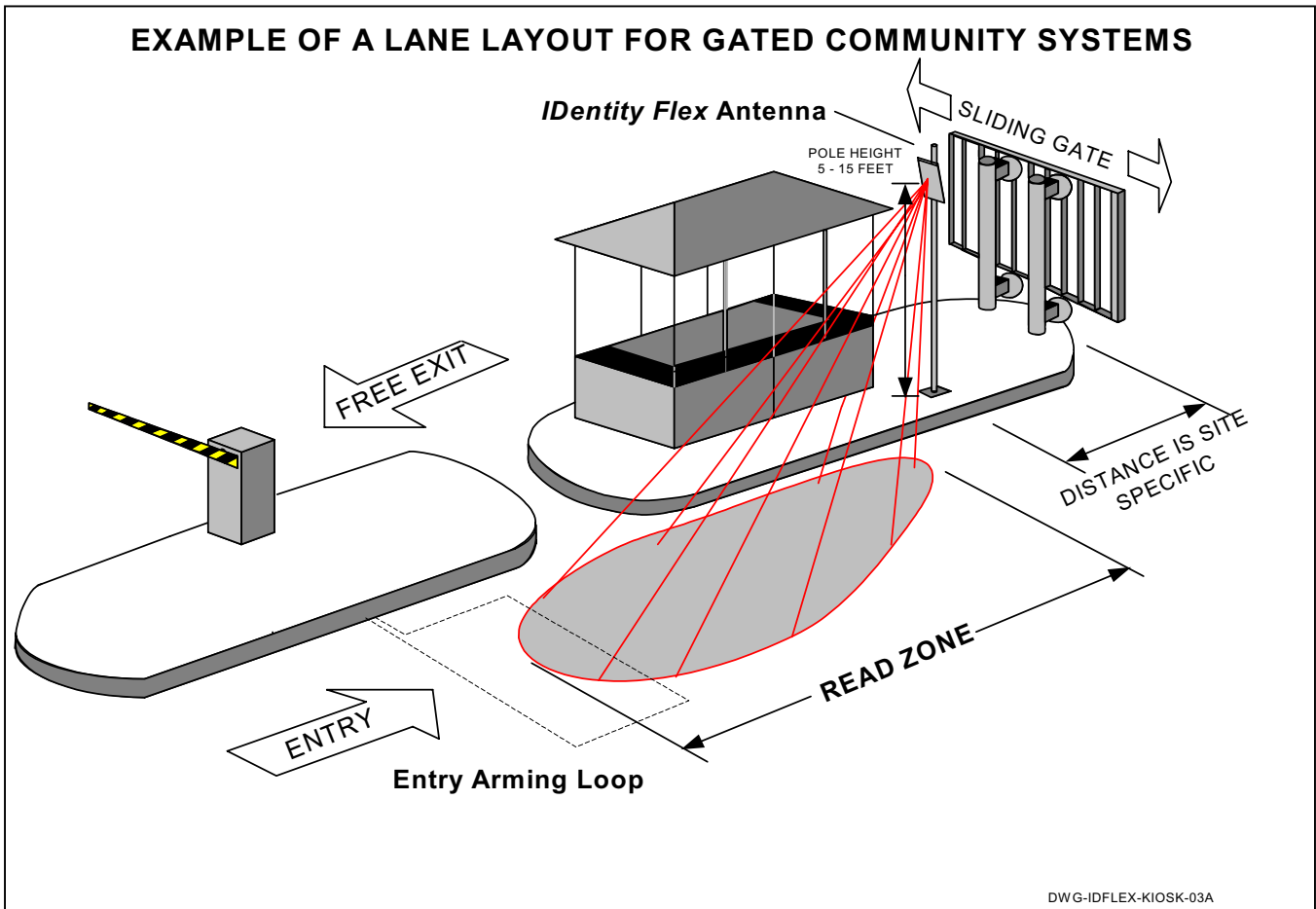

**Figure 2.2 – Typical Gated Access Lane Configuration**

In addition considerations for Parking Access, the Gated Access system installer may include the following options in the installation plan.

### **Use of Entry Presence Loops**

Entry presence loops can be utilized to arm the SIRIT reader. Depending on the application, presence loops may or may not be required. Figure 2.2 shows a typical gated configuration with an arming loop. For more information, please contact your dealer or Sirit.

## Use of S-Flex Transponder

Gated Access systems may have a requirement for SIRIT's Break on Removal (BOR) S-Flex transponder. The main difference between the S-Flex transponder and the standard IDentity Flex transponder is that the S-Flex transponder will deactivate once it is removed from the windshield. In addition, **users should be made aware of proper test procedures for testing for metal-oxide windshields prior to permanently affixing the S-Flex transponder to the windshield.** These procedures can be found on page 51.

## Gate Output Relays

Gated Access systems may require that SIRIT activate the gate directly from the SIRIT IDentity Flex reader. SIRIT makes relays and mounting components available as an option.

## Memory Gates

Memory gates or the use of SIRIT's reader buffer circuit (If the IDentity Flex reader controls the gate directly) may be required. This will be a requirement if the antenna and read zone are further away from the gate (beyond 10' as in Parking Access systems). The read zone could be, for example, up to 50 feet away. However, this may create unwanted access due to an unauthorized vehicle getting stuck between two authorized vehicles.

If a facility wishes to place the antenna read pattern beyond 10 feet there may not be a concern with unwanted access. Placing the antenna read distance far away allows time for the gate to open so vehicles do not have to slow down and this may be desirable. At some entry points, booths may be manned and this reduces the risk of any lane logic issues.

## Use of T21 (Tolling Application) Transponders

Gated Access systems can accommodate users who have SIRIT's T21 tolling application transponders. The T21 transponder serial numbers will have to be converted and entered into each reader's database to output the desired facility code and ID.

## Desktop Reader

In certain situations, Gated Access sites may have a large number of T21 transponders to enter into the reader's database. To make this task easier SIRIT

makes available an optional desktop reader which allows each tag to be scanned into the database. Users can scan in the source tag Identification number and then assign a destination or output identification number containing a facility code and ID. Each *IDentity Flex* reader is capable of storing up to 10,000 translated T21 transponders in its database.

## **Antenna Mounting**

Gated Access systems may require that the SIRIT antenna be mounted lower in height compared to Parking Access systems. In order to ensure consistent reads SIRIT recommends that the antenna be mounted at 10-15 feet above the island. Please consult with SIRIT if lower antenna heights are desirable.

Installers of Gated Access systems should also review lane logic considerations for Parking Access systems as some of the sections (e.g. Antenna LED's – Tag read indicator and SIRIT Pre-site assistance) will also apply.

## ***MULTIPLE READER INSTALLATIONS***

### **Multiple Local or Remote Readers**

Gated Access systems may have multiple local or multiple remote readers. If configurations or tag databases need to be updated SIRIT has a number of options available. SIRIT can support up to 60 local readers through optional smart switches. Local readers can be connected up to 4 miles away with the use of optional short haul modems. If access is required to readers that are located beyond the 4-mile limit SIRIT makes available dial-up capabilities using optional US Robotics® 56K external modems. Multiple local or remote reader access requires the use of SIRIT's Windows®-based *IDentity Flex* software.

Instructions for configuring the *IDentity Flex* system for multiple readers can be found on page 40. Additional information can be found in the Windows®-based *IDentity Flex* software manual.

## **Remote Antenna Mounting**

### ***REMOTE ANTENNA MOUNTING OPTIONS***

#### **Overhead**

For overhead installations, antenna brackets are bolted to ceilings at a height of no more than 15 feet above the driveway. Antennas brackets are adjusted to

produce an antenna angle of between 5 to 45 degrees from horizontal, tilted towards oncoming traffic. Should there be an obstruction in the lane center such as a lamp or conduits, adjustment of the UMB will allow an additional sideways tilt of up to 45 degrees to compensate for the offset from lane center. Consider adding vehicle clearance signs to prevent damage to the antennas from oversize vehicles. It is important that any reflective surfaces such as metal signs or metal height restriction bars are not placed in the antenna's read zone.

## Side-Mounting

*IDentity Flex* antennas may be mounted on vertical poles or horizontal pipes utilizing the supplied UMB or CWB. Note that each antenna requires two (2) coaxial cable feeds, one being *Transmit*, the other *Receive*. Cables may be clamped to walls with clips or run through appropriate conduits.

# Equipment Placement and Cable Routing

## READER LOCATION

Many factors can determine the location of the *IDentity Flex* reader in an installation.

There are two primary requirements:

- The reader must be accessible for maintenance purposes;
- There must be a source of AC power for the reader.

Secondary considerations include:

- The reader may need to be in a secure area such as inside a toll kiosk or gatehouse;
- Locating the reader in close proximity to the host system interface results in a single maintenance location;
- It may be more cost-effective to have the reader as close as possible to the antenna locations since runs of coaxial cable and I/O wiring are more expensive per foot than the Wiegand interface cable to the host systems;
- The reader must be within a cable-run distance of 200 feet from the furthest antenna;
- Cost will be minimized by having a centrally-located reader with respect to the remote antenna locations;
- Although mounted in a robust NEMA 4X enclosure, readers should be placed in a location that will not unnecessarily expose them to harsh operating or climatic conditions such as extreme heat or cold, salt splashes and corrosive chemicals.

Once a decision is made on the location for the *IDentity Flex* reader, the installer can move on to cable selection.

## REMOTE ANTENNA CABLE AND CONDUIT SELECTION

### Antenna Cable Selection

If the cable run between the reader and the remote antenna is less than 50 feet use Belden 8240, RG-58/U cable.

If the cable run between the reader and the remote antenna is more than 50 feet, to a maximum of 200 feet, use Belden 9913 cable.

Remote antenna coaxial leads require cable connectors at each end and each is different. Refer to Table 2.1 and Table 2.2 below for selection of the coaxial cables and connectors required.

**Table 2.1 – Remote Antenna Cable Selection**

Distance, Reader to Antenna	Recommended Cable Type	Cable Diameter Inches/mm	Attenuation per 50 Feet of Cable, dB
0 – 50 Feet	Belden 8240, RG-58/U	0.195/4.95	7.25 dB
50 – 200 Feet	Belden 9913	0.404/10.29	2.25 dB

### Conduit Selection

Antenna coaxial cable runs can be fastened in place with clips, but it is recommended that all cable be housed in conduit to protect the wiring from adverse weather, property maintenance tools and, to some degree, electromagnetic interference (EMI).

Communication and antenna cabling can share the same conduit but it is recommended that a separate conduit be used for AC power if required.

Ensure conduit diameter is sufficient to house at least two cables per antenna. For example, two Belden 9913 cables with OD 0.404" require 0.808" of diameter, or 1" conduit. If ¾" conduit were selected for RG-58/U cabling and later circumstances required a change to Belden 9913, two 9913's would not fit inside the ¾" conduit. When making conduit size selection, allow for shielded twisted pair wires for each input and output circuit at each read point because there may be up to two circuits for each channel. If a site will be installed without the LED Tag Read Indicator antennas, and a retrofit may be desired later, increase conduit size to accommodate the 2 conductor 18 AWG cable.

## REMOTE ANTENNA CABLE CONNECTORS

Use the following table to determine which precision UHF coaxial connectors are required for the installation. All cable ends require connectors.

**Table 2.2 – Antenna/Reader Connector Selection**

Where Used	Cable Type	Manufacturer Number
Antenna Connector	RG-58/U	Amphenol 82-5375
Reader Connector	RG-58/U	AMP 226600-1
Antenna Connector	9913	Amphenol 82-202-1006
Reader Connector (Adapting cable jumper)	9913 - See Figure 3.10 on page 33 (CABLECON is RG-58/U)	Amphenol 82-202-1006 and “CABLECON” adapter

For Belden 8240 (RG-58/U) cable, installers will need to provide connectors. SIRIT can provide these by quoting part # IDFLEX-CONN-RG-58/U. Each kit contains enough connectors to install one antenna (two (2) Amphenol 82-5375 and two (2) AMP 226600-1).

For Belden 9913 cable, installers will need to provide connectors. SIRIT can provide these by quoting part # IDFLEX-CONN-9913. Each kit contains enough connectors to install one antenna (four (4) Amphenol 82-202-1006 connectors). For Belden 9913 cable installers will need to convert from 9913 to a mini-UHF connector at the reader end. An 18” adapter cable is used to adapt the N Type connector on the 9913 cable to the reader’s Mini-UHF input. See Figure 3.10 on page 33 for adapter options. SIRIT can provide cable converter kit as an option by quoting part # IDFLEX-CABLECON.

**Installers must use the proper crimping tool to install the above connectors.** Installers can purchase this item locally (Amphenol CTL-5) or SIRIT can provide this as an option by quoting part # IDFLEX-CRIMP. **Sirit recommends that outside connectors be weatherproofed by applying proper weather-proof tape.** First, mastic tape is applied to the dry connector, then covered with electrical tape. Tape kits are available from Sirit by quoting part number IDFLEX-CONN-WKIT.



### Cable Kits

The following Table 2.3 provides a list of pre-made cables available from Sirit:

**Table 2.3 – Cable Kit**

Description	Manufacturer Number
2 ea 50’ RG-58/U Cable, N connector attached, 2 mini UHF Connector assembly	IDFLEX-CABLE-RG58/U-60K

## AC POWER CONNECTIONS

The reader accepts 85 to 265 VAC 47-440 Hz input power. Line, neutral and safety ground connections are provided via the included power cord with 120 VAC three-prong plug. Check with local authorities for any additional local regulations.

When a customer orders a unit wired for 240 VAC power, it is supplied with a standard 120 VAC three-prong plug. If an alternative plug is required, the customers will be required to provide their own power plug.

Use the correct wire and appropriate power and ground connections for all connections in accordance with the local electrical regulations.

## List of Materials

### HARDWARE INSTALLATION TOOLS

Hardware installation will require the following tools:

- Standard hand tools
- Adjustable wrenches
- Wire stripper
- Crimping tool as per connector manufacturer's guidelines
- Digital multimeter
- Soldering tools

### INTERFACE / DIAGNOSTIC TOOLS

Software and configuration setup will require the following:

- Laptop computer or PC running ProComm™, Windows® HyperTerminal™ or Sirit *IDentity Flex* Windows software.
- Serial cable (Pin-to-Pin) with DB-9 male connector for connection to the reader. **DO NOT USE A NULL MODEM CABLE!**
- IDentity Flex Antenna part # IDFLEX-ANT-01
- IDentity Flex Reader – 2-Channel or 4-Channel
- Quantity 2 – 10 feet RG-58/U test cables with connectors



# 3. Installation

Installation typically follows this sequence:

- Remote Antenna Installation
- Reader Installation
- Quick Power-On Test
- Antenna Lead Installation
- Cable Connector Installation
- Interface Connections
- Transponder Usage

The following sections detail the procedures for completing the installations.

## Remote Antenna Installation

Remote antenna locations will have been decided during the Pre-Installation process. A description of this process begins on page 10. Refer to Figure 3.1, 3.2 and 3.3 for antenna orientation positions.

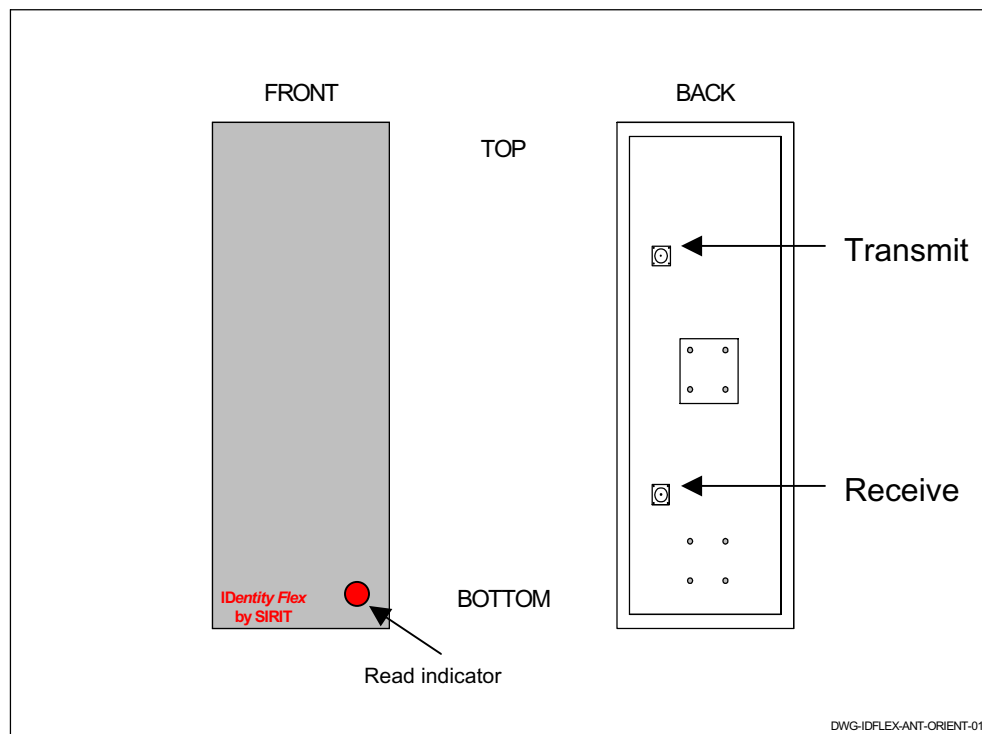

Figure 3.1 – Antenna Orientation



Note that the front of the antenna is the flat side with the SIRIT logo. The rear of the antenna contains the cable connectors and mounting bracket studs. The bottom of the antenna is the end closest to the end-located mounting studs. See page 24. **Do not drill any holes in the antenna assembly. Drilling holes will internally damage the antenna rendering it inoperable.**

The orientation of the antenna is shown in Figure 3.1, with the *IDentity by Sirit* logo easily readable in the bottom left-hand corner. Antennas should be installed to position the radiated beam centered in the lane. The center of the antenna should be 10-15 feet above the ground. Ensure that no metal is placed in front of the antenna in its final adjusted position.

Antennas may be affixed to the ceiling, to poles, pipes or conduits with SIRIT's Universal Antenna Mounting (UMB) bracket and cables dressed to poles or pipes. See Figure 1.2 on page 7 and Figure 3.3 on page 23 for some recommended mounting options.

Shielded signal or communications cables such as low voltage may be run through the same conduit as the antenna leads where allowed by law. Power cables such as high voltage should not be run through the same conduit as the antenna leads.

Figure 3.4 on page 24 details the connections for the antenna and cables.

**NOTE:** Readers with S/N greater than 321 have the LED signal incorporated into the **receive** line. To ensure the proper functionality of the LED it is necessary to ensure the transmit and receive cables from the reader are connected to the corresponding connector on the back of the antenna. The connectors are labeled on the back of the antenna to assist in proper connection.

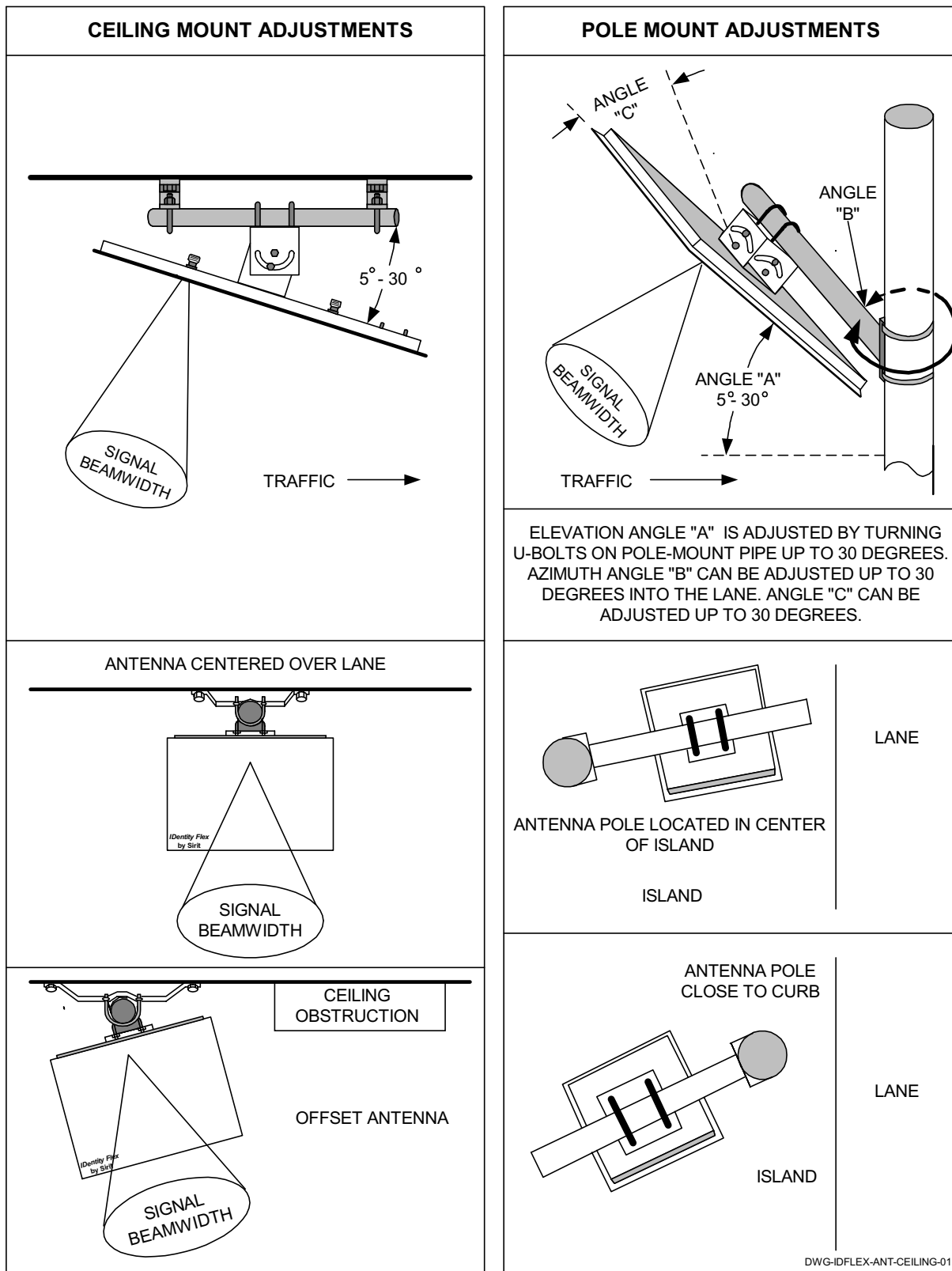

DWG-IDFLEX-ANT-CEILING-01

Figure 3.2 – Antenna Mounting Angles

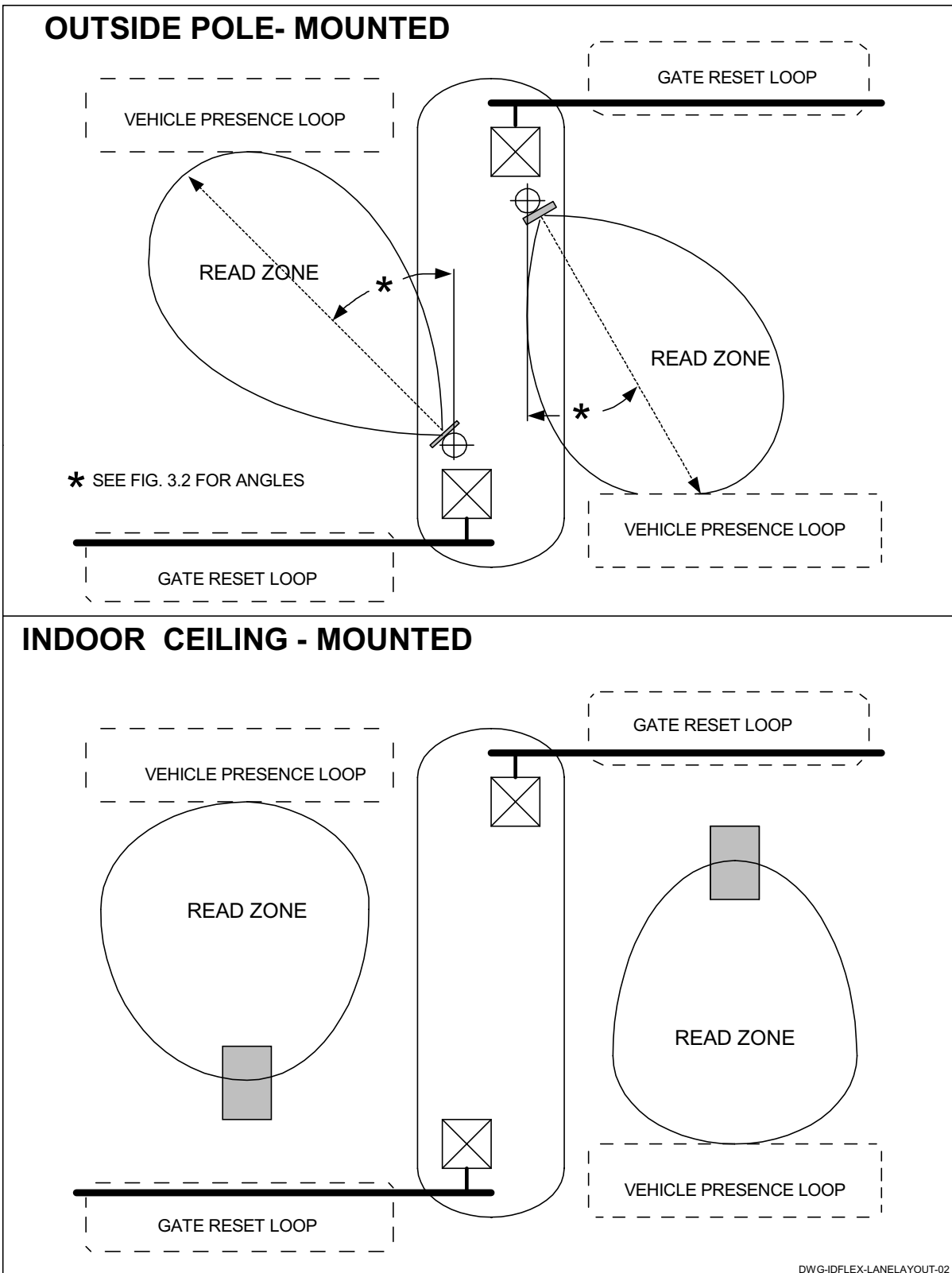

Figure 3.3 - Antenna Lateral Orientation

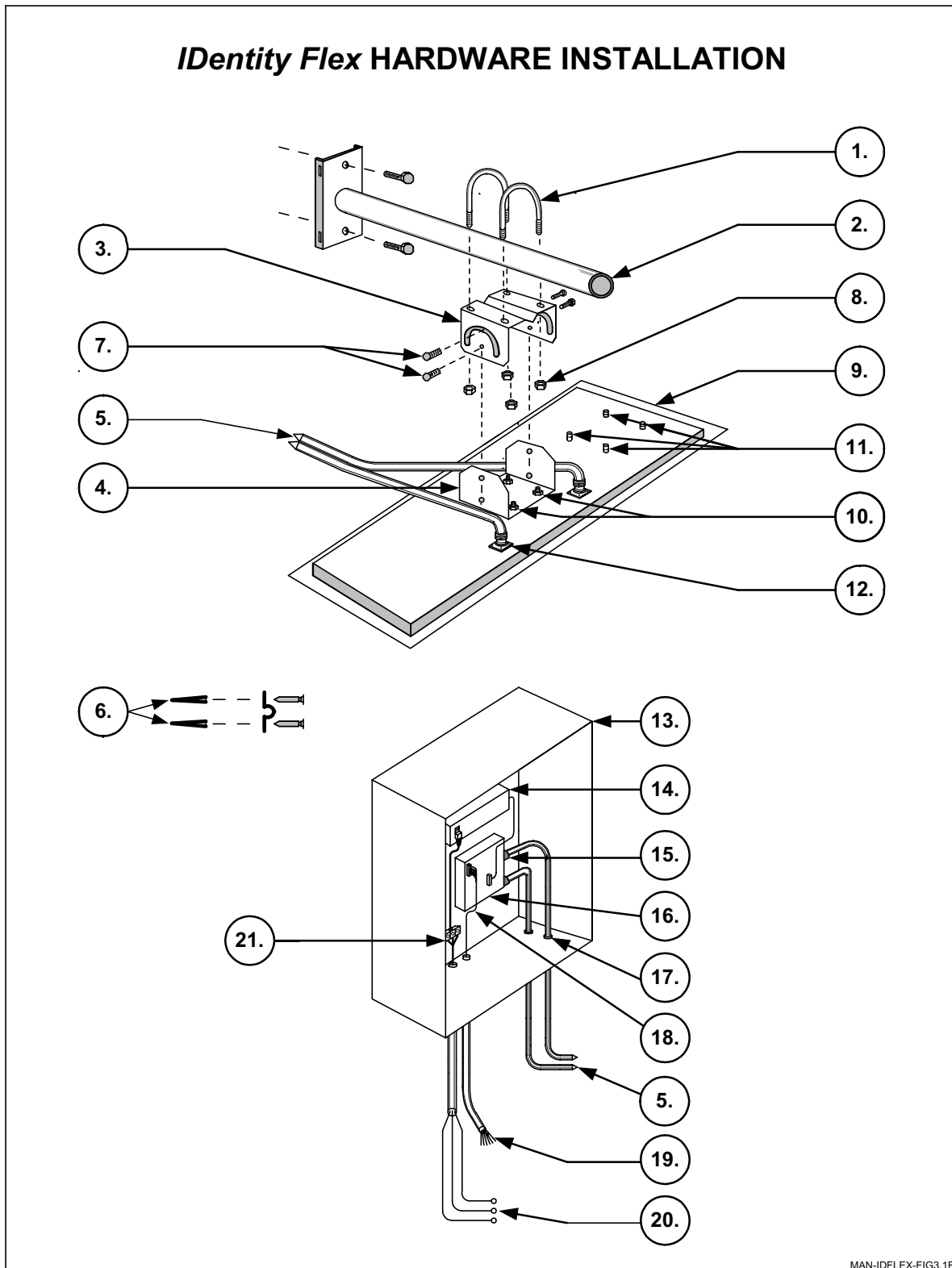

Figure 3.4 – Remote Antenna/Reader Connection Diagram

**Table 3.1 – Legend for Figure 3.4**

<b>Item No.</b>	<b>Description</b>	<b>Supplied by SIRIT</b>
1	U-Bolts, antenna mounting bracket, 2 per bracket	✓
2	WMB, pipe, mast or conduit used for antenna mount	
3	UMB Antenna bracket half, conduit mount side	✓
4	UMB Antenna bracket half, antenna mount side	✓
5	Coaxial cables, 50 Ohm, See Table 2.1 (p. 17)	
6	Concrete lag bolts or screws and cable clamps	
7	Bracket pinning bolts, 2 required	✓
8	Nuts for U-bolts, 4 per bracket	✓
9	<i>IDentity Flex</i> antenna assembly, shown facing down	✓
10	Bracket mounting nuts, ¼-20, 4 per bracket	✓
11	Alternate studs, for various mounting options	✓
12	Coaxial Type-N connector, see Table 2.2 (p. 18)	
13	NEMA 4X Enclosure or utility waterproof housing	✓
14	<i>IDentity Flex</i> power supply	✓
15	Coaxial Mini-UHF connector, see Table 2.2 (p. 18)	
16	<i>IDentity Flex</i> reader, showing one antenna connected	✓
17	Conduit or cable bushing in NEMA box	
18	Wiegand or interface lines to controlled circuits	
19	Multi-conductor cable fan-out to interfaces	
20	AC power line to service panel	
21	AC power line terminal strip	

# Reader Installation

The reader location will have been determined during the pre-installation process after consideration of the factors described on page 16. The reader should be mounted prior to cutting cable lengths to ensure correct measurement. Figure 3.5 following shows the basic cabling arrangement inside the reader.

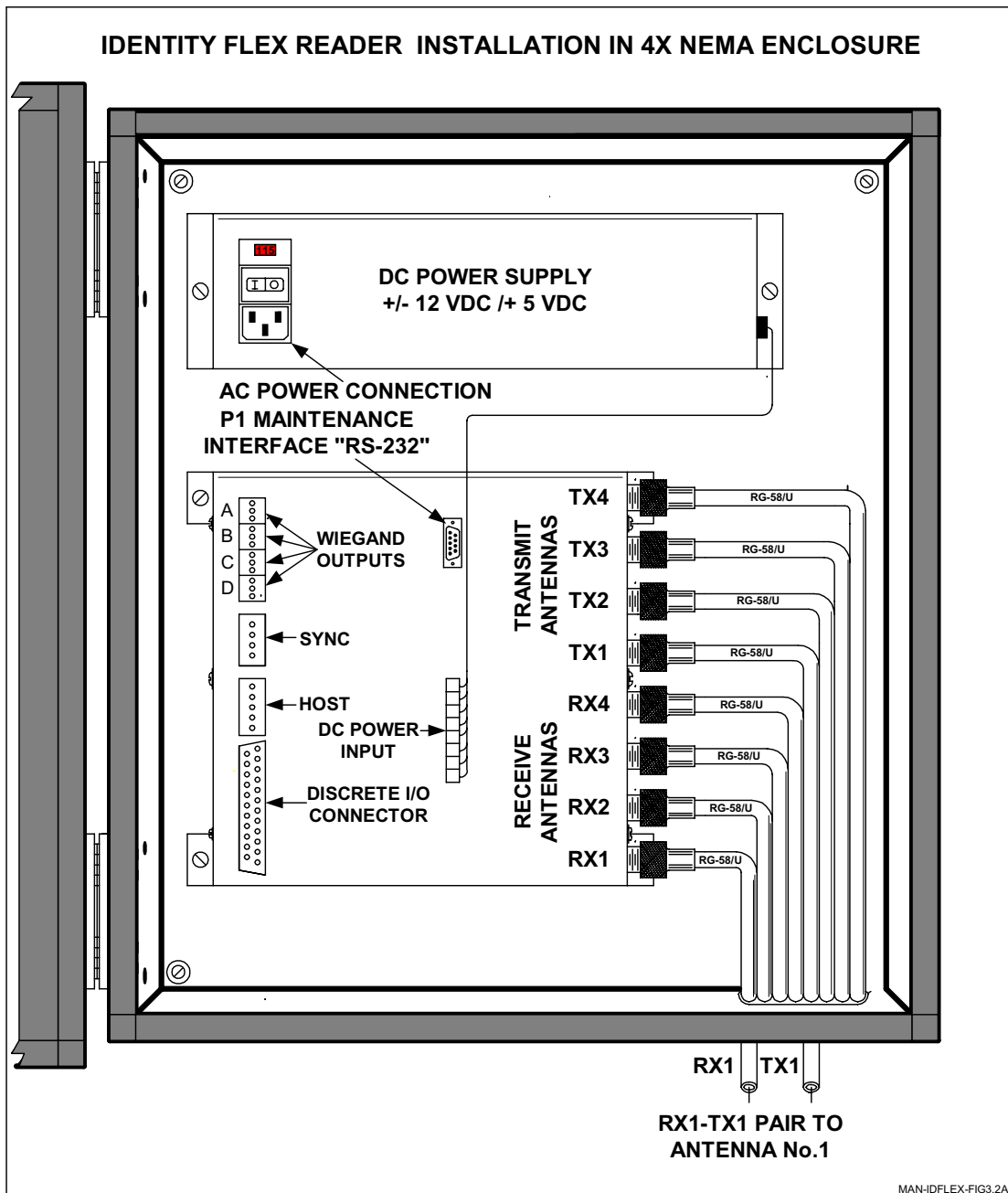

Figure 3.5 – Reader Connections

## Quick Power-On Test

A Quick Power-On Test is used to verify power connections and correct operation of the reader after shipping.



**1) CAUTION: HIGH VOLTAGE PRESENT.**

- 2) Ensure that the reader power switch is in the OFF (O) position
- 3) Connect a power cable from the receptacle in power supply to AC Outlet.
- 4) Connect appropriate antennas. If antenna cables are not yet ready, complete the following section to attach the antenna leads to all enabled channels. **DO NOT ENABLE RF POWER TO A PORT WITH NO ANTENNA OR DUMMY LOAD CONNECTED.**



- 5) Turn the reader power switch ON (I).
- 6) The Sync Indicator LED (7) should come ON except if the unit is a slaved part of a synchronized installation where the master is OFF.
- 7) The CPU Active LED (8) should flash to indicate CPU operation.
- 8) Turn the reader power switch OFF (O).
- 9) Disconnect the power cable from the AC outlet.

## Antenna Lead Installation

### Coaxial Cable

Antenna leads are the cables that connect the reader with the remote antennas. Two cables are required for each antenna – one for *Transmit* and one for *Receive*.

If the cable run between the reader and the remote antenna is less than 50 feet use Belden 8240, RG-58/U cable.

If the cable run between the reader and the remote antenna is more than 50 feet, to a maximum of 200 feet, use Belden 9913.

### Conduit

Install the conduit, if required, between the reader and the remote antenna locations. In some cases, it may be beneficial to pre-insert the cable before fastening or burying the conduit.

Ensure conduit diameter is sufficient to house at least two cables per antenna. For example, two Belden 9913 cables with OD 0.404" require 0.808" of diameter, or 1" conduit. If ¾" conduit were selected for RG-58/U cabling and later circumstances required a change to Belden 9913, two 9913's would not fit inside the ¾" conduit. When making conduit size selection, allow for shielded twisted

pair wires for each input and output circuit at each read point because there may be up to two circuits for each channel. If a site will be installed without the LED Tag Read Indicator antennas, and a retrofit may be desired later, increase conduit size to accommodate the 18 AWG twisted pair shielded cable.

## Cable Connector Installation

Precision UHF coaxial connectors are required on all cable ends. ***Prepare cable ends exactly as shown in the following pages. Failure to follow exact dimensioning will considerably degrade system performance.*** After assembly, check the cables for short circuits with an ohmmeter and attach the antenna leads to the readers and antennas as shown in Figure 3.4 on page 24 and Figure 3.5 on page 26.



***Installers must use the proper crimping tool to install the following connectors.*** You can purchase this item locally (Amphenol CTL-5) or SIRIT can provide this as an option by quoting part # IDFLEX-CRIMP. ***Sirit recommends that outside connectors be weather-proofed by applying mastic tape over dry connectors then covering with electrical tape.*** Weather-proofing kit is available from Sirit by quoting part number IDFLEX-CONN-WKIT.



### ***RG-58/U CABLE***

For Belden 8240, RG-58/U cable installers will need to provide connectors. Each antenna requires (2) Amphenol 82-5375 and (2) AMP 226600-1 or SIRIT can provide this as an option by quoting part # IDFLEX-CONN-RG-58/U. Figure 3.6 , Figure 3.7 and Figure 3.8 detail installation of the connectors for RG-58/U cable starting on page 29.

### ***BELDEN 9913 CABLE***

For Belden 9913 cable installers will need to provide connectors. Each antenna requires (4) Amphenol 82-202-1006 connectors or SIRIT can provide these as an option by quoting part # IDFLEX-CONN-9913. Figure 3.9 on page 32 details installation of the connectors for Belden 9913 cable.

### ***ANTENNA CABLE ADAPTER***

For Belden 9913 cable installers will need to convert from 9913 to a mini UHF connector at the reader end. SIRIT can provide cable converter kit as an option by quoting part # IDFLEX-CABLECON. Figure 3.10 on page 33 details assembly of the Antenna Cable Adapter.

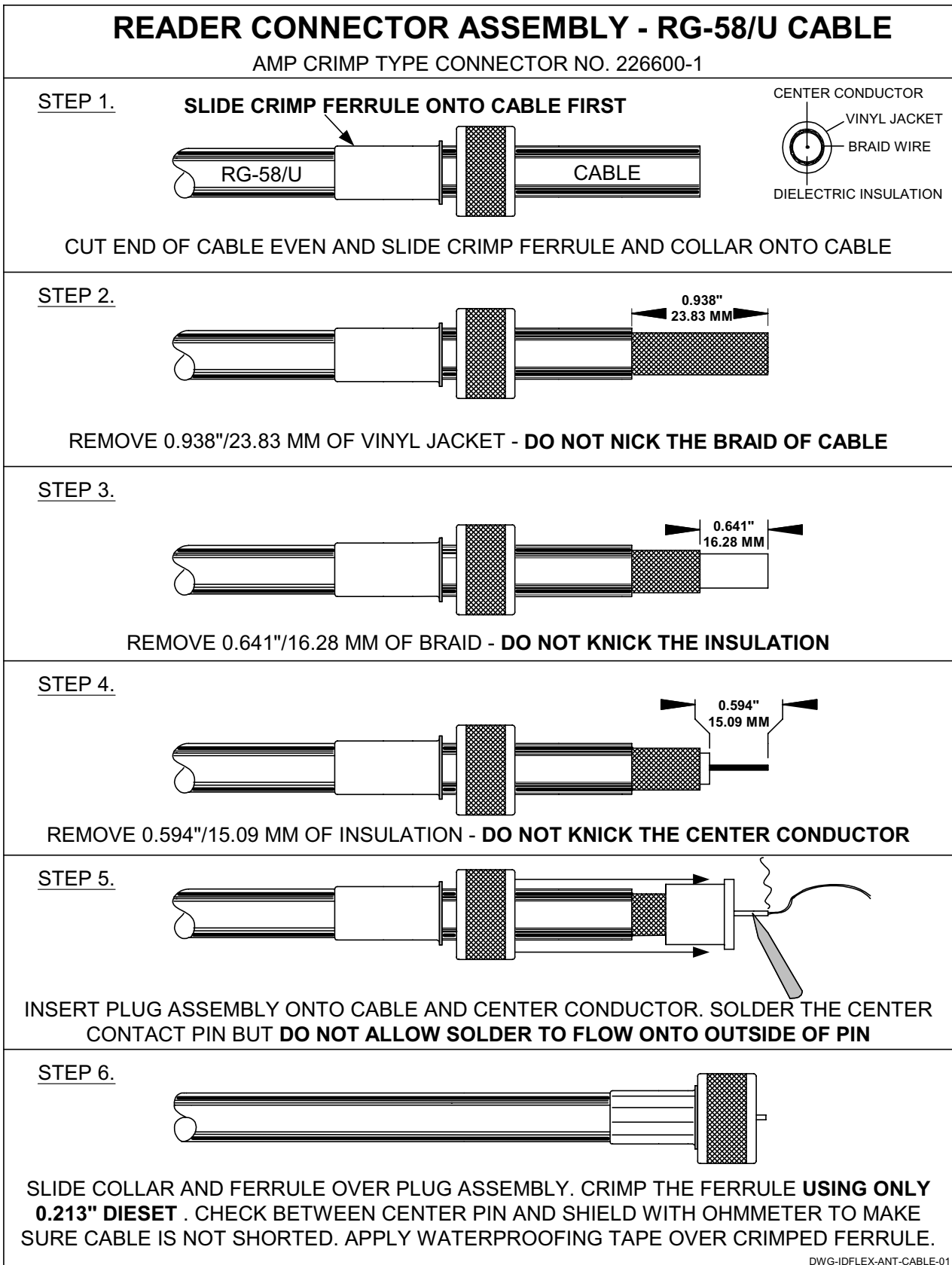

Figure 3.6 – RG-58/U Amp 226600-1 Installation

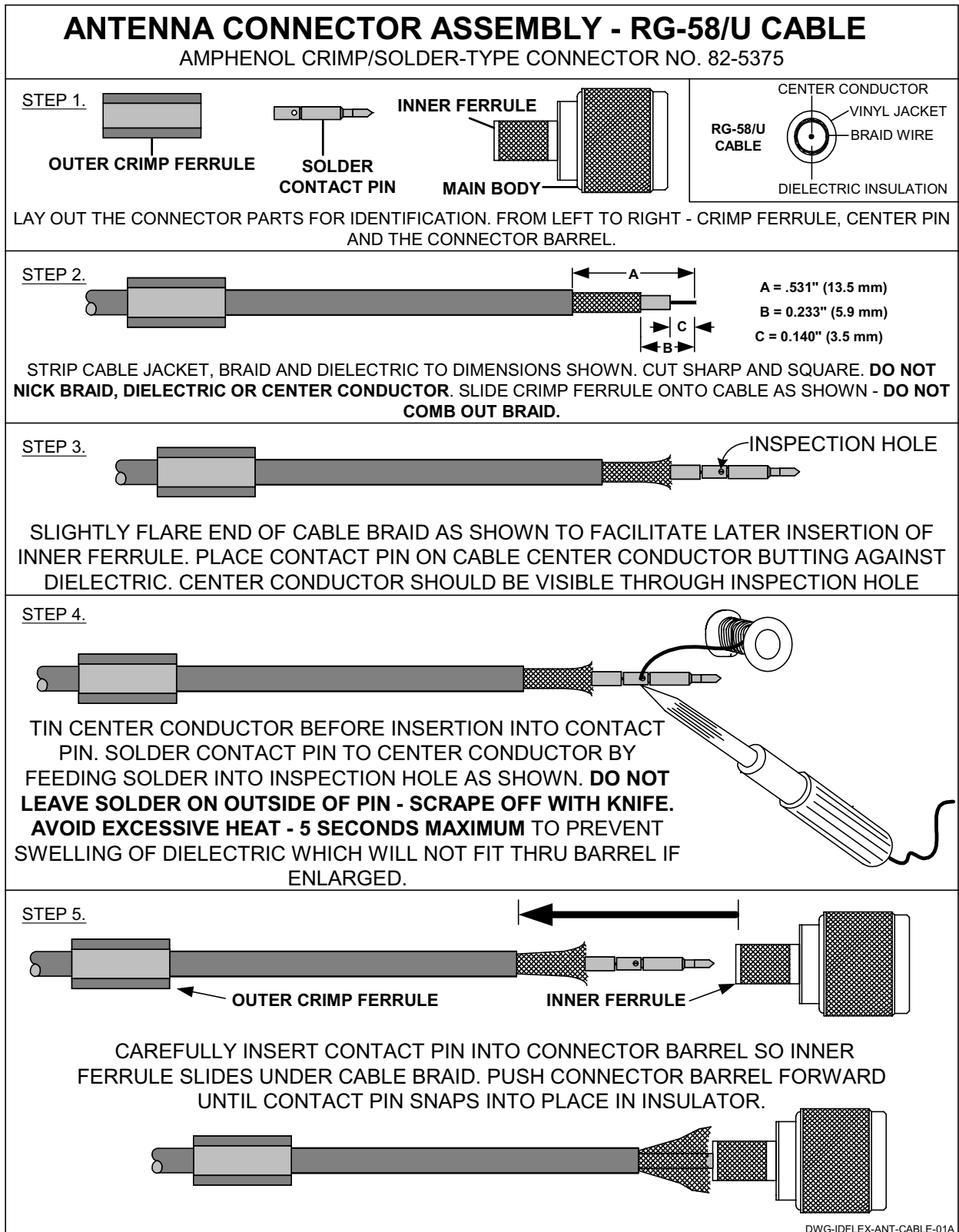



Figure 3.7 – RG-58U Amphenol 82-5375 Installation (Part A)

### CABLE CONNECTOR INSTALLATION - RG-58/U CABLE

AMPHENOL CRIMP-TYPE CONNECTOR NO. 82-5375 ON ANTENNA END OF CABLE

**STEP 6.**



CONTACT PIN MUST SNAP IN AT SAME TIME AS BRAID BUTTS UP AGAINST CONNECTOR BODY AS SHOWN BELOW



**STEP 7.**

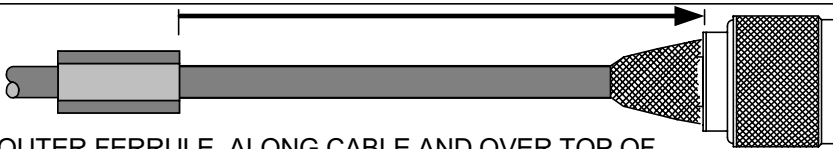

SLIDE OUTER FERRULE ALONG CABLE AND OVER TOP OF BRAID AND UP AGAINST THE CONNECTOR BODY.

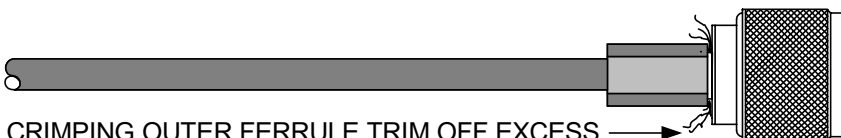

AFTER CRIMPING OUTER FERRULE TRIM OFF EXCESS BRAID WIRES WITH SHARP KNIFE .

**STEP 8.**

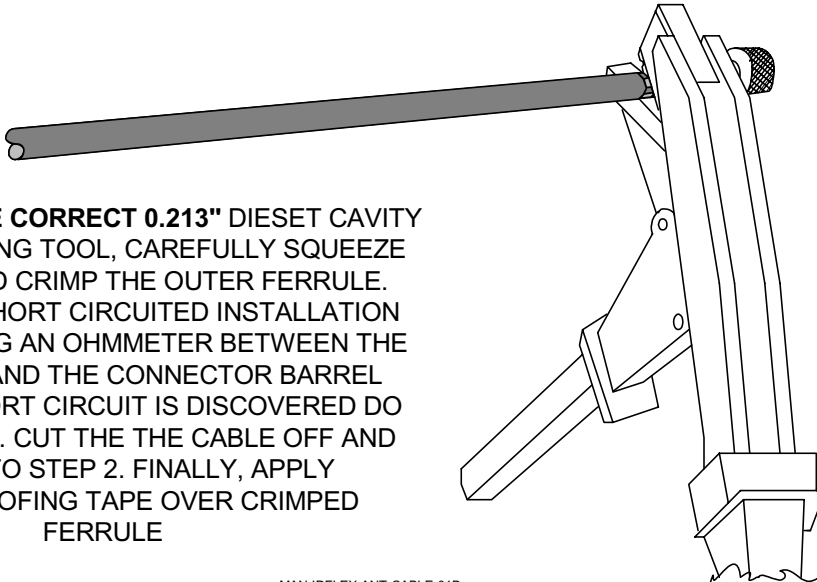

USING **ONLY THE CORRECT 0.213"** DIESET CAVITY ON THE CRIMPING TOOL, CAREFULLY SQUEEZE THE TOOL AND CRIMP THE OUTER FERRULE. CHECK FOR SHORT CIRCUITED INSTALLATION BY CONNECTING AN OHMMETER BETWEEN THE CENTER PIN AND THE CONNECTOR BARREL BODY. IF A SHORT CIRCUIT IS DISCOVERED DO NOT PROCEED. CUT THE THE CABLE OFF AND RETURN TO STEP 2. FINALLY, APPLY WATERPROOFING TAPE OVER CRIMPED FERRULE

MAN-IDFLEX-ANT-CABLE-01B

**Figure 3.8 - RG-58U Amphenol 82-5375 Installation (Part B)**

## CONNECTOR ASSEMBLY - BELDEN 9913

AMPHENOL N-TYPE CONNECTOR NO. 82-202-1006

STEP 1.	CLAMP NUT	WASHER	GASKET	
	9913		CABLE	CENTER CONDUCTOR VINYL JACKET BRAID WIRE DIELECTRIC INSULATION

CUT END OF CABLE EVEN AND SLIDE NUT, WASHER AND V-GROOVE WASHER ONTO CABLE.  
ENSURE V-GROOVE OPENINGS POINT TOWARD END OF THE CABLE AS SHOWN.

STEP 2. 0.359"  
9.1 MM

REMOVE 0.359"/9.1 MM OF VINYL JACKET - **DO NOT NICK THE BRAID OF CABLE**

STEP 3. 0.234"  
6 MM

COMB OUT BRAID AND FOLD OUT THEN BARE CENTER CONDUCTOR FOR 0.234"/6 MM

STEP 4. CLAMP

PULL BRAID WIRES FORWARD AND TAPER TOWARD CENTER CONDUCTOR. PLACE CLAMP  
OVER BRAID AND PUSH CLAMP BACK AGAINST END OF CABLE JACKET AS SHOWN.

STEP 5. CONTACT PIN

TRIM BRAID TO PROPER LENGTH AND FOLD BACK BRAID WIRES OVER CLAMP. TIN CENTER  
CONDUCTOR AND SOLDER CONTACT PIN INTO PLACE. SCRAPE ANY EXCESS SOLDER OFF  
OF PIN SO IT WILL BE A PRECISION FIT THROUGH HOLE IN CONNECTOR BODY.

STEP 6. *CONTACT PIN MUST NOT  
BE VISIBLE FROM THE  
SIDE. IF VISIBLE, CABLE  
END IS IMPROPERLY  
PREPARED! START OVER*

INSERT CABLE AND PARTS INTO CONNECTOR BODY. ENSURE SHARP EDGE OF CLAMP SEATS PROPERLY INTO  
GASKET. TIGHTEN NUT (ARROW) INTO CONNECTOR BARREL **USING 2 WRENCHES MAKING SURE CONNECTOR  
BARREL DOES NOT TURN ON THE CABLE**. NOTE THAT THE CONTACT PIN MUST NOT EXTEND OUT OR BE  
VISIBLE FROM THE SIDE. FINALLY, APPLY WATERPROOFING TAPE OVER NUT AND BARREL.

DWG-IDFLEX-ANT-CABLE-04

**Figure 3.9 – Belden 9913 Amphenol 82-202-1006 Installation**

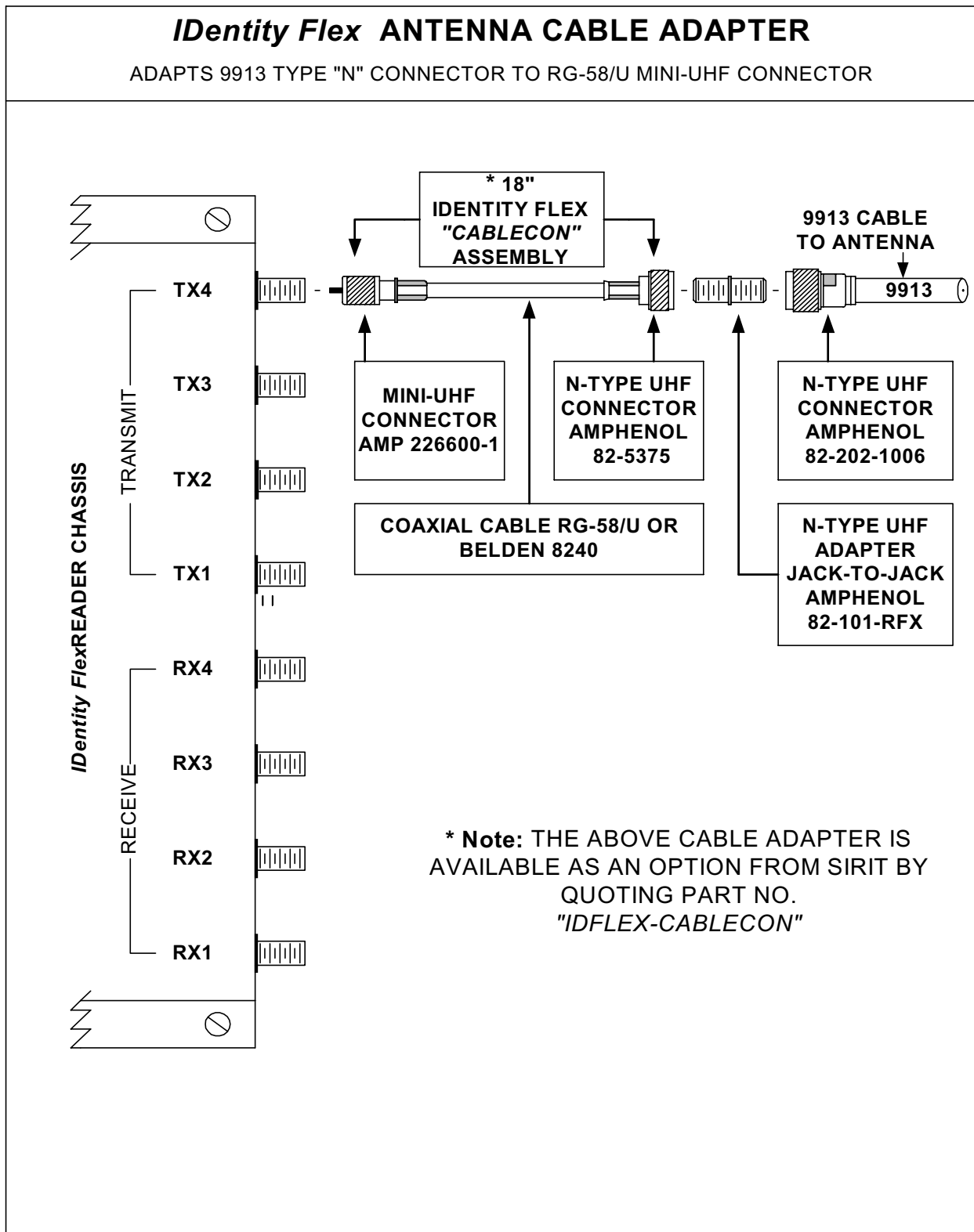

Figure 3.10 – Antenna Cable Adapter Connection

# Interface Connections

## SYSTEM INTERFACES

The following sections contain descriptions of interfaces, interface connectors, jumper settings and sync line connectors that will be connected in the field.

Once installed and wired, the entire *Identity Flex* system is configured from a PC or laptop running *SIRIT's Identity Flex software, ProComm™ or Windows® HyperTerminal™*. The configuration is done on site at the reader location by connecting a PC's serial port to the Maintenance Interface identified as "RS-232". This configuration may also be performed remotely by use of a dial-up modem and SIRIT's Windows®-based *Identity Flex* software. Refer to Figure 3.11 below for the reader chassis layout.

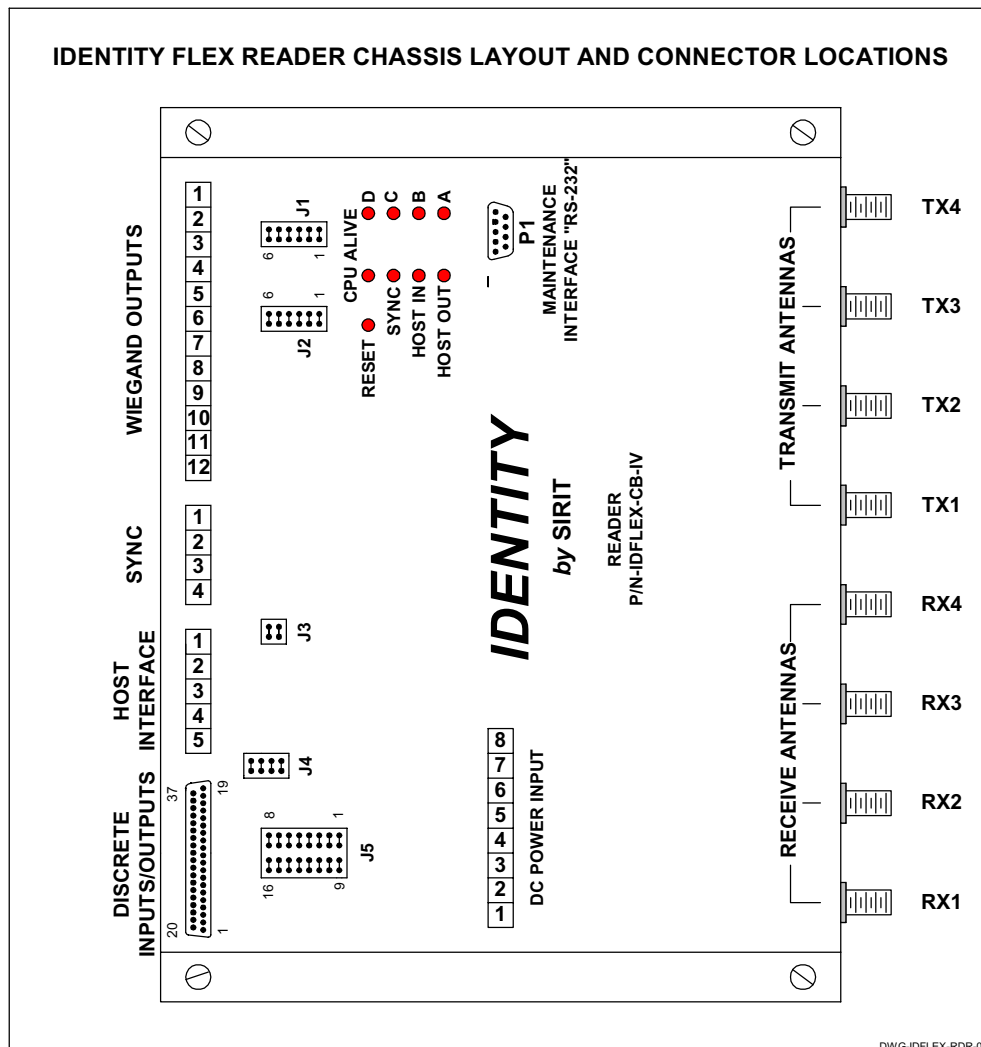

Figure 3.11 – Identity Flex Reader Connections

## SERIAL HOST CONNECTIONS – RS-232, RS-422, RS-485<sup>1</sup>

All RS-232 connections are made to the DB9F connector identified as “RS-232” also referred to as the maintenance port or maintenance interface. The Tx, Rx, and Gnd connections are made to pins 2, 3 and 5 respectively.

RS-232 cable should be a shielded pin-to-pin serial cable – not a Null Modem cable.

RS-232 connections should not exceed 50 feet in length.

For long distances, RS-232 to RS-422 or RS-232 to RS-485<sup>1</sup> converters should be employed. RS-422 connections can communicate at distances up to 4000 feet. RS-422 connections require four wires: two, individually shielded, twisted pairs.

**Table 3.2 – Maintenance Port Pin-outs**

Pin	Signal Function
1	N/C
3	RxD
5	Ground
7	Reset
9	N/C
2	TxD
4	Dload
6	N/C
8	N/C

### MAINTENANCE COMPUTER CONNECTION

The maintenance computer interface allows the user to configure the reader system for the specific application, up-load operating software and transponder translation lists. The *IDentity Flex* Windows®-based software additionally permits downloading operational configuration information. Further, the maintenance computer interface allows testing of the system’s transmitter, receiver and all discrete inputs and outputs.

The DOS-based *IDentity Flex* software manual gives a complete listing of all menus and sub-menus available via the maintenance interface. To connect to the maintenance interface, the host computer requires emulation software such as HyperTerminal™ or ProComm™. ProComm™ emulation software is recommended. HyperTerminal™ emulation software does not allow for system software or translation table software uploading. Table 3.3 below lists emulation settings.

<sup>1</sup> Custom RS-485 connections specified by SIRIT

**Table 3.3 – Emulation Settings**

Baud Rate	9600
Data Bits	8
Stop Bits	1
Parity	None
Flow Control	None

## SYSTEM HOST INTERFACE CONNECTOR AND JUMPERS

Based upon which host protocol is being utilized, the host interface port may be configured for RS-232, RS-422 or RS-485<sup>2</sup>. The supplied 5-pin host interface connector is configured for communication with any of the above listed data transmission protocols. Connections for these should be made as follows:

**Table 3.4 – Host Interface Connector Pin Functions**

Cable	Pin 1	Pin 2	Pin 3	Pin 4	Pin 5
RS-232	Ground	Tx-	Tx+	Rx+	Rx-
RS-422	Gnd	NC	RS-232	RS-232	NC
RS-485 <sup>2</sup>	Gnd	RS-422-	RS-422+	RS-422+	RS-422-
		NC	NC	RS-485+	RS-485-

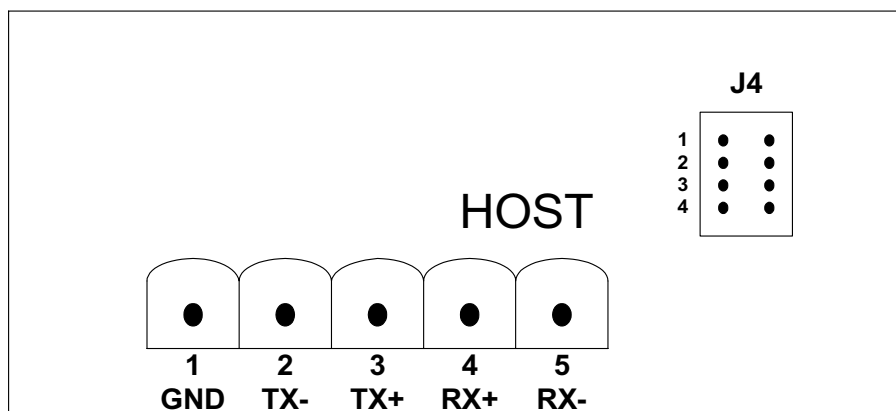

**Figure 3.12 – Host Interface Connector and Jumpers**

<sup>2</sup> Custom RS-485 connections specified by SIRIT

### SYSTEM HOST INTERFACE JUMPERS

The jumpers located above the host port connector labeled J4 are used to enable the RS-485 function and apply the appropriate transmission line resistive termination. If the reader being configured is the last device on a multi-drop network, the host connector must be terminated using J4-3 and J4-4 inserted.

- J4-1 RS-485+ connection to Host Connector Pin 4
- J4-2 RS-485- connection to Host Connector Pin 5
- J4-3 Connection for termination resistor to Host Connector Pin 3
- J4-4 Connection for termination resistor to Host Connector Pin 4

### WIEGAND COMMUNICATIONS CONNECTIONS

The Wiegand Interface can be user selectable to any of the standard Wiegand bit formats. The Wiegand interface is essentially the transmission of data 1 (5 V) or data 0 (0 V). The Wiegand output protocol may be configured for data stream bit lengths from 26 to 34 bits. The first and last bits of the data stream are parity bits and not part of the tag id.

Example: To convey a 23 bit data word length, the Wiegand data bits would be configured for 26 bits.

For other customized Wiegand formats, please contact SIRIT for more information.

Wiegand cables are interfaced to the reader at the connector designated as “WIEGAND OUTPUTS”.

Wiegand cables should be made using two, individually shielded, twisted-pairs (i.e., a four-wire cable). Each pair should carry one of the data lines and a ground line (i.e., pair one - Data 0 and GND, pair two - Data 1 and GND).



Whenever connectors or jumpers are to be removed **TURN OFF AC POWER FIRST!**

**Table 3.5 – Wiegand Interface Specifications**

26 Bit Wiegand Interface	34 Bit Wiegand Interface
Total 26 bits	Total 34 Bits
Parity Bits Positions 0 and 25	Parity Bits Positions 0 and 33
High parity bit Even (1-12)	High Parity Bit Even (1-16)
Low Parity Bit Odd (13-24)	Low Parity Bit Odd (17-32)
Most Significant Bit Sent First	Most Significant Bit sent First

## WIEGAND HOST INTERFACE CONNECTOR

A 12-positon screw-terminal connector is provided for the Wiegand interface.

**Table 3.6 – Wiegand Connector Pin-outs**

Pin	Signal	Pin	Signal
1 Channel A	Port 1 – Data 0	7 Channel C	Port 3 – Data 0
2 Channel A	Port 1 – Data 1	8 Channel C	Port 3 – Data 1
3 Channel A	Port 1 – Ground	9 Channel C	Port 3 – Ground
4 Channel B	Port 2 – Data 0	10 Channel D	Port 4 – Data 0
5 Channel B	Port 2 – Data 1	11 Channel D	Port 4 – Data 1
6 Channel B	Port 2 – Ground	12 Channel D	Port 4 – Ground

## WIEGAND PORT JUMPER CONFIGURATION

(Jumpers that enable the WIEGAND Ports)

Each of the reader’s four multiplexed remote antennas has an independent Wiegand Communications port. These 4 ports each have an independent Data 0, a Data 1 and Ground connection at the terminal block connection labeled Wiegand Outputs. Each may be enabled (jumpers in) or disabled (jumpers out) as desired. The following is a table identifying each of those jumper connections.

**Table 3.7 – Wiegand Jumper Port Layout**

Jumper Designator	Jumper Function	Jumper Designator	Jumper Function
J1-1 Channel "A"	W1-D0+5VDC PU	J2-1 Channel "C"	W3-D0+5VDC PU
J1-3 "A"	W1-D1+5VDC PU	J2-3 "C"	W3-D1+5VDC PU
J1-2 "A"	W1 Ground	J2-2 "C"	W3 Ground
J1-4 Channel "B"	W2-D0+5VDC PU	J2-4 Channel "D"	W4-D0+5VDC PU
J1-6 "B"	W2-D1+5VDC PU	J2-6 "D"	W4-D1+5VDC PU
J1-5 "B"	W2 Ground	J2-5 "D"	W4 Ground

If jumpers are installed, they provide internal 5-volt DC pull-ups and ground, i.e. Data 0, Data 1 lines and Ground output connections. See Figure 3.13 below showing a typical Pull-Up circuit schematic.

If no jumpers are installed the external Wiegand wiring going to the host system is opto-isolated from all reader electronic circuitry., The host system will be required to provide it’s own logic level pull-up voltage and ground.

## INTERNAL WIEGAND PULL UP CIRCUIT

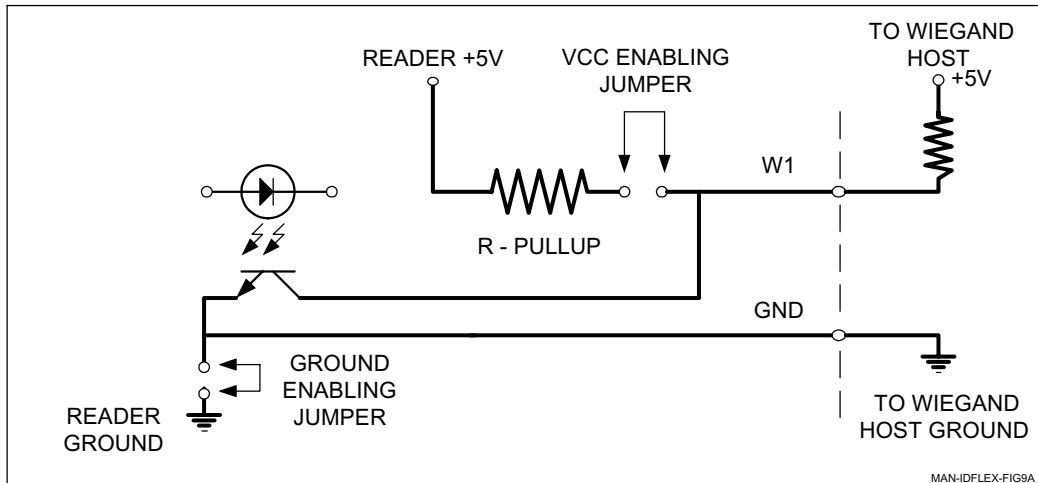

Figure 3.13– Typical Internal Wiegand Pull-up Circuit

Configuration Menu options accessible via the RS-232 Maintenance port allow bit length, data direction and other protocol options to be set for each of the Wiegand Ports.

## IDENTITY FLEX READER - SYNC PULSE CHARACTERISTICS

In multi-reader installations, where readers must be synchronized but fail to synchronize, connections can be verified using an oscilloscope. The following sync pulse train characteristics are observed on a functional reader, where it leaves a Master reader or arrives at a Slave. These differential voltages can also be observed and measured on a peak-reading meter as shown but if an RMS meter is utilized, indicated readings will be reduced by 50 to 75%. An example is a peak voltage of 8 volts will read on an RMS meter as approximately 2 Volts and will be fluctuating.

Placing measurement probe on + terminals

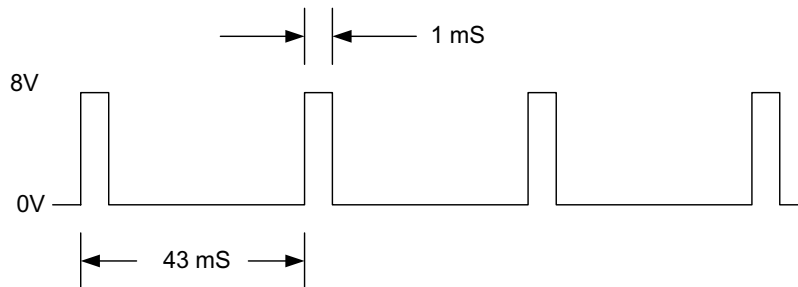

Placing measurement probe on - terminals

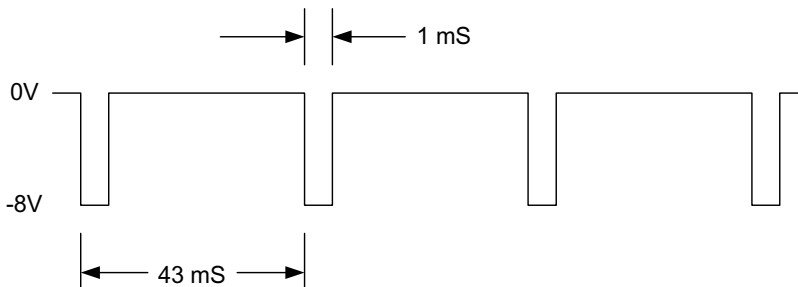

DWG-IDFLEX-SYNC-01

Figure 3.14 - Sync Pulse Characteristics

## MULTIPLE READER INSTALLATIONS

Installations that utilize more than one reader with adjacent lanes close to other readers require synchronization. Synchronization allows all separate readers to transmit simultaneously so that they do not interfere with each other. Synchronization is accomplished by connecting the reader systems in a daisy chain fashion where a Previous-to-Next convention is established.

Once connected, the reader system automatically determines which reader system will generate the synchronization signal and become the master. Slaves will receive and respond to the synchronization signals. If the readers are not synchronized, the transmitted signals may interfere with one another, preventing tag reads.

Separate readers with adjacent lanes must be synchronized. Two or more separate systems with their antennas closer than 100 feet must be synchronized.

All sync cables are shielded twisted pairs (recommended is use of AWG 18 or 20). The sync cables are connected to terminals labeled “SYNC”.

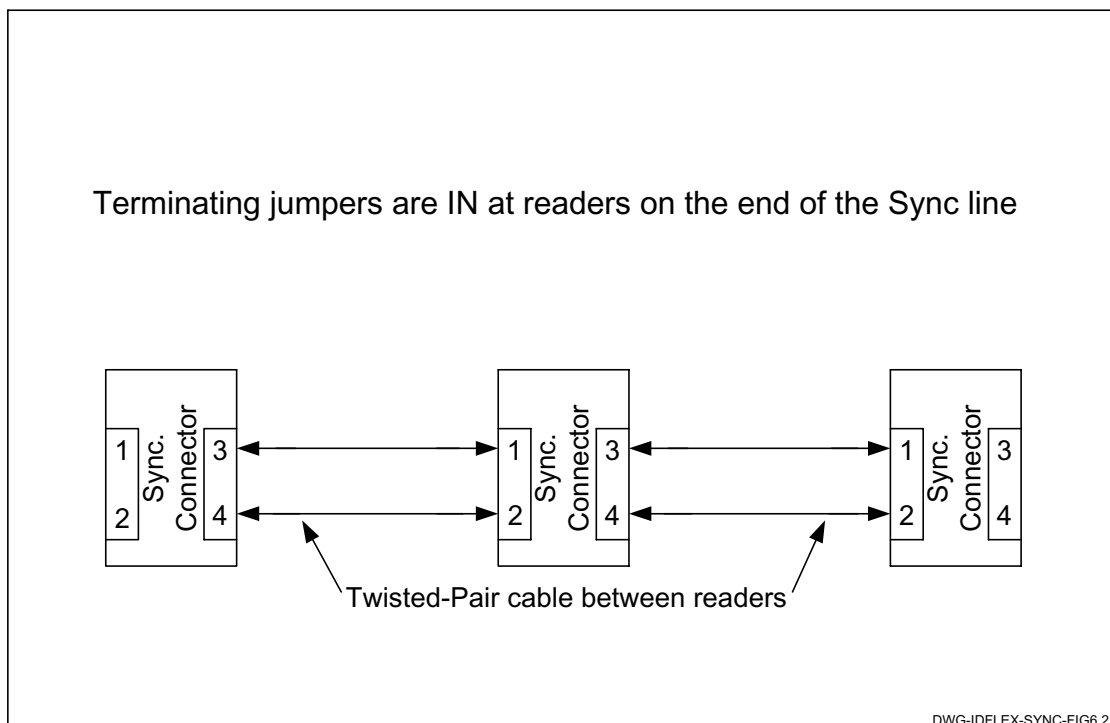

**Figure 3.15 – Multiple Reader System Sync Connections**

## SYNC TERMINATION JUMPERS JP1, JP2

J3 jumpers located above and to the right of the sync connection terminals are utilized to install transmission line termination resistors for reader systems that are located on the end of the daisy chain. In the example above, reader systems 1 and 3 would have both jumpers installed in J3 pin one and two. Reader system #2 would have no jumpers installed.

## SYNC INTERFACE CONNECTOR J3

Pin 1	Sync +	(to Previous Reader System)
Pin 2	Sync –	(to Previous Reader System)
Pin 3	Sync +	(to Next Reader System)
Pin 4	Sync –	(to Next Reader System)

## DISCRETE I/O CONNECTOR J5

Table 3.8 that follows is a listing of the discrete I/O connector pinout and signals available at the 37-pin DISCRETE I/O CONNECTOR, J5.

- Discrete Input signals are TTL compatible.
- Discrete Output signals are jumper configurable to provide either a +5 VDC or +12 VDC signal for driving low-current solid-state relay control circuitry.
- Each output jumpered for 5 volts is current limited to 100 mA short circuit current.
- Each output jumpered for 12 volts is current limited to 42 mA short circuit current.
- The 37-pin female D connector is normally provided by SIRIT.

## DISCRETE INPUTS AND OUTPUTS

Table 3.8 – 37-Pin Discrete Input / Output Connector J5

Pin Number	Signal Name	Pin Number	Signal Name
J5-1	LAMP OUTPUT CH. A	J5-20	GATE COMMAND OUTPUT CH. A
J5-2	Lamp Output Ch. B	J5-21	Gate Command Output Ch. B
J5-3	Lamp Output Ch. C	J5-22	Gate Command Output Ch. C
J5-4	Lamp Output Ch. D	J5-23	Gate Command Output Ch. D
J5-5	VCC *	J5-24	VCC *
J5-6	VCC *	J5-25	VCC *
J5-7	VCC *	J5-26	VCC *
J5-8	VCC *	J5-27	VCC *
J5-9	VCC *	J5-28	Entrance Loop Input Ch. A
J5-10	Gate Position Input Ch. A	J5-29	Entrance Loop Input Ch. B
J5-11	Gate Position Input Ch. B	J5-30	Entrance Loop Input Ch. C
J5-12	Gate Position Input Ch. C	J5-31	Entrance Loop Input Ch. D
J5-13	Gate Position Input Ch. D	J5-32	GND
J5-14	GND	J5-33	GND
J5-15	GND	J5-34	GND
J5-16	GND	J5-35	GND
J5-17	GND	J5-36	GND
J5-18	GND	J5-37	GND
J5-19	GND		

\* Warning: Any connection to these pins by customer may cause severe damage to reader. Please contact Sirit technical support prior to making any connection.

**IMPORTANT NOTE:** Utilize only one jumper per discrete output. **Do not attempt to configure any one output, that is Output 1-1 for both a +5VDC and +12VDC output at the same time by installing both jumpers JP5-9 and JP5-10 or power supply damage may result.**



## J5 DISCRETE OUTPUT JUMPERS JP1-JP16

Table 3.9 – Jumper Pin-out and Function Table

Jumper Pin #	Jumper Function
1	Gate Output A (+5VDC)
2	Lamp Output A (+5VDC)
3	Gate Output B (+5VDC)
4	Lamp Output B (+5VDC)
5	Gate Output C (+5VDC)
6	Lamp Output C (+5VDC)
7	Gate Output D (+5VDC)
8	Lamp Output D (+5VDC)
9	Gate Output A (+12VDC)
10	Lamp Output A (+12VDC)
11	Gate Output B (+12VDC)
12	Lamp Output B (+12VDC)
13	Gate Output C (+12VDC)
14	Lamp Output C (+12VDC)
15	Gate Output D (+12VDC)
16	Lamp Output D (+12VDC)

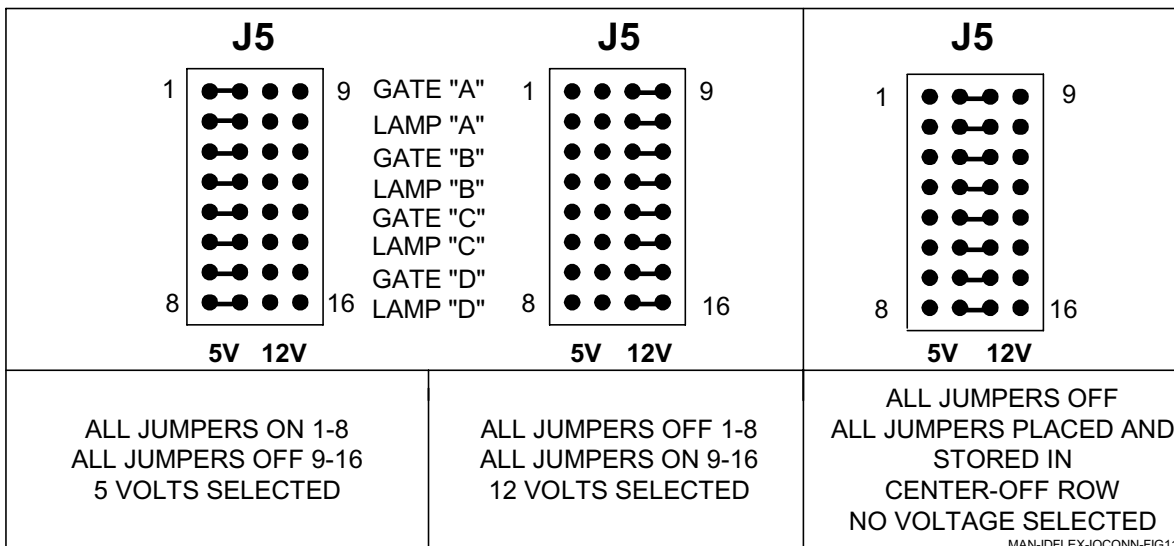

Figure 3.16 – Discrete Input/Output Jumpers

## DISCRETE INPUT/OUTPUT FUNCTIONS

Two discrete outputs are provided per reader port. The discrete outputs provide control signals for the Lane Indicator Light (Lamp Output) and the Lane Gate (Gate Command). The driving signals are open collectors with jumper-selectable pull-up voltages of either +5 VDC or +12 VDC. If no jumpers are installed, the current-sinking capability of the open collector device is 150 mA. If either jumper is installed, the driving capability of the pull-up voltages is restricted to low current control of devices such as solid-state relays. The pull-up outputs are not intended to directly drive magnetic relays.

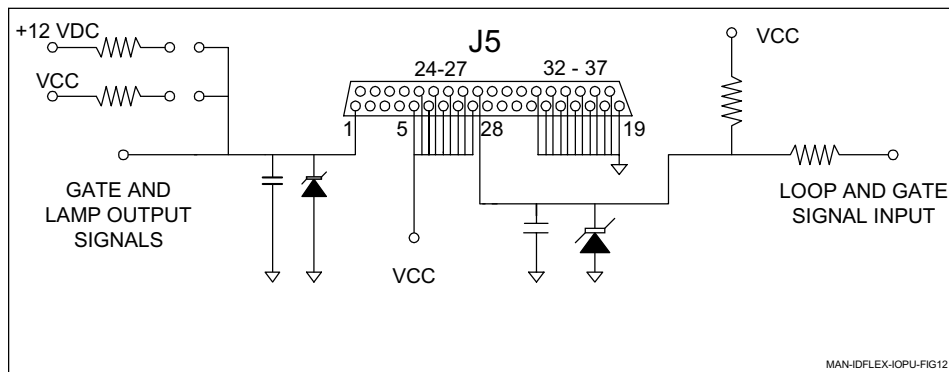

Figure 3.17 – Typical Input / Output Circuit and Pull- Up Resistors

## DISCRETE INPUT POLARITY

There are two discrete inputs per reader channel. The inputs are the Entry Loop and Gate Position signals. The reader will respond to either an active high or active low signal for these inputs based upon how the reader is configured. The activation levels are configurable via the configuration menus. See Figure 3.18.

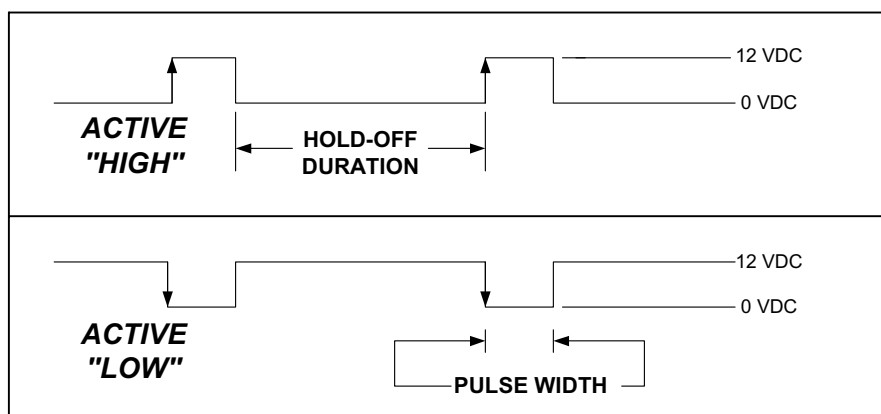

Figure 3.18 – Examples of Active-High and Active-Low Polarities

## DISCRETE OUTPUT POLARITY, PULSE WIDTH AND DELAY

There are two discrete outputs per reader channel. The outputs are LAMP and GATE. The active levels for both of these outputs are configurable to active high or active low. The Pulse Width and mandatory time delay between successive output pulses are also configurable via the configuration menus.

## OPTO-ISOLATED RELAY CONTROL BOARD

As an option, SIRIT offers 4-module or 16-module opto-isolated relay motherboards that provides either AC or DC input modules to satisfy the switching requirements of a wide range of lamps and gates. The pre-wired relay motherboard interfaces to J5, the 37-pin I/O connector and provides terminal-block connections for peripheral device wiring. The cable assemblies for the relay boards and the relay support panel are also provided in the option package.

### Gate Input or Loop Input Relays

Under certain conditions users may elect to arm (turn on) the SIRIT antenna based upon a change of state of a gate position or loop output circuit. Arming the antenna can be accomplished by using the gate position input or both inputs tied in series.

Two methods are available for this purpose:

#### Dry Contact Switch or Relay

A dry contact relay (no voltage being applied) is connected between the reader's discrete I/O connector ground and desired discrete input pin. The active logic level for the discrete input (reader responds to either a high or low) may be configured via the input polarity mask in the system setup menu. No outside voltage source is required or desired to provide a discrete input signal to the reader. If noise or voltage is unintentionally placed on either the ground or discrete input lines connected to the reader, a second isolation relay will break the noisy circuit.

#### AC or DC Input Relay Module

The second method of activating a discrete input is by using an opto-isolated input relay module. The modules are designed to accept either an AC or DC input signal within the modules specified operating range. The advantage to using the opto-isolated module is that it presents an optical barrier between the input equipment and the reader.

## Gate Output or Lamp Output Relays

Under certain conditions users may elect to have the *IDentity Flex* reader system vend a gate or lamp output directly. Under these conditions SIRIT makes available an opto-isolated output relay module that can handle either AC or DC. The relay module typically drives the gate or lamp's control relay input. Connection in this fashion provides an optical barrier between the output circuit and the SIRIT reader.

This relay is required as there is typically a load voltage on the controlled side of the gate or lamp output relay.

## Relay Wiring

Relay wiring tables can be found in the section starting on page 65.

## **MEMORY GATE OPERATION**

The reader supports operations with memory and non-memory lift gate devices. A lift gate operates in the following fashion:

- A command is issued by the reader to the gate controller which will lift the gate mechanism.
- The vehicle which was read will move under the gate.
- The gate remains up until the vehicle exits the gate area and crosses an exit indicator mechanism such as a road-embedded pickup loop.
- The controller then determines that the vehicle has left and lowers the gate.

## **NON-MEMORY LIFT GATE**

The gate will only respond to a gate up command if it is in the "DOWN" position. There is no memory provision to store additional gate "UP" commands that may be sent by the reader while the gate is "UP". "GATE UP" commands generated by the reader during the time that the gate is up will be lost.

Identity Flex reader operations with non-memory lift gates require that a gate position feedback mechanism be employed from the lift gate to the reader and that the reader be configured to operate with non-memory lift gates. Based upon the specific gate, the feedback signal may be an opening or closing contact when the gate is in the “UP” position. The feedback signal is connected to the Gate Position Discrete Input for the lane in use. When configured for non-memory gate operation, the reader will not send a “GATE UP” command to the gate controller if the feedback signal is in an ACTIVE state. Once the feedback signal goes to an in-active state, the next in-queue “GATE OPEN” command will be sent. See Figure 3.19 following for a typical schematic.

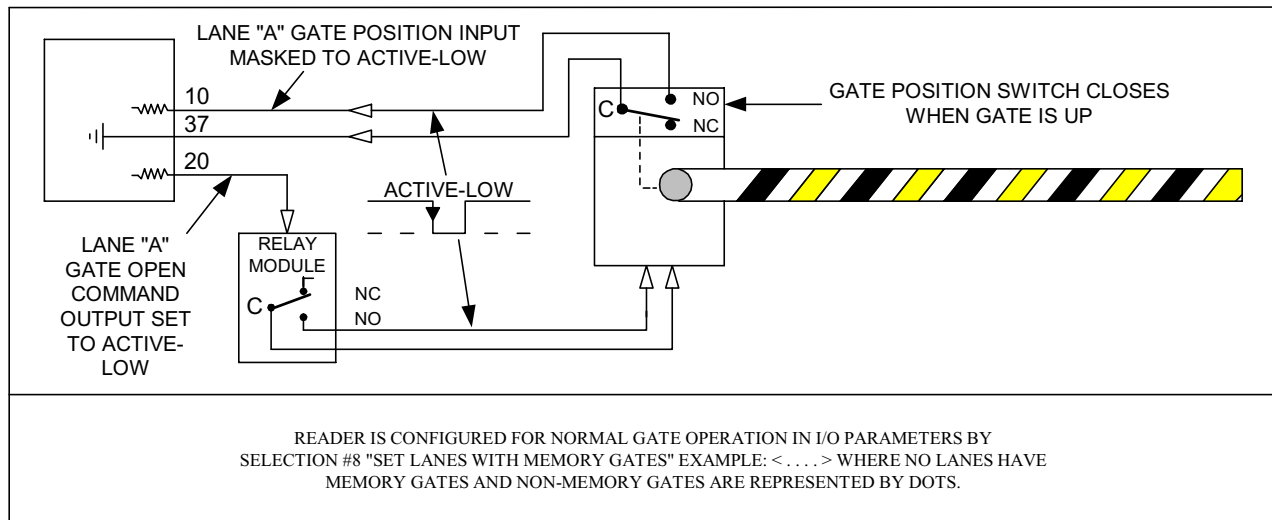

Figure 3.19 – Identity Flex Non-Memory Lift Gate Operation

## MEMORY LIFT GATE OPERATION

“GATE UP” commands sent by the reader to the gate controller while the gate is in the down position will lift the gate. “GATE UP” commands sent by the reader to the gate controller while the gate is in the “UP” position will be stored in the gate controller memory. When the gate lowers, the next in-queue “GATE UP” command will lift the gate. This process will continue until all “GATE UP” commands have been utilized emptying the memory buffer. No gate position feedback mechanism between the gate controller and the reader is necessary. The reader will send a “GATE UP” command to the gate controller at the time that they are created by a vehicle read event. The operational condition of the gate controller has no effect on reader operations. Please refer to Figure 4.10 below for the memory gate schematic.

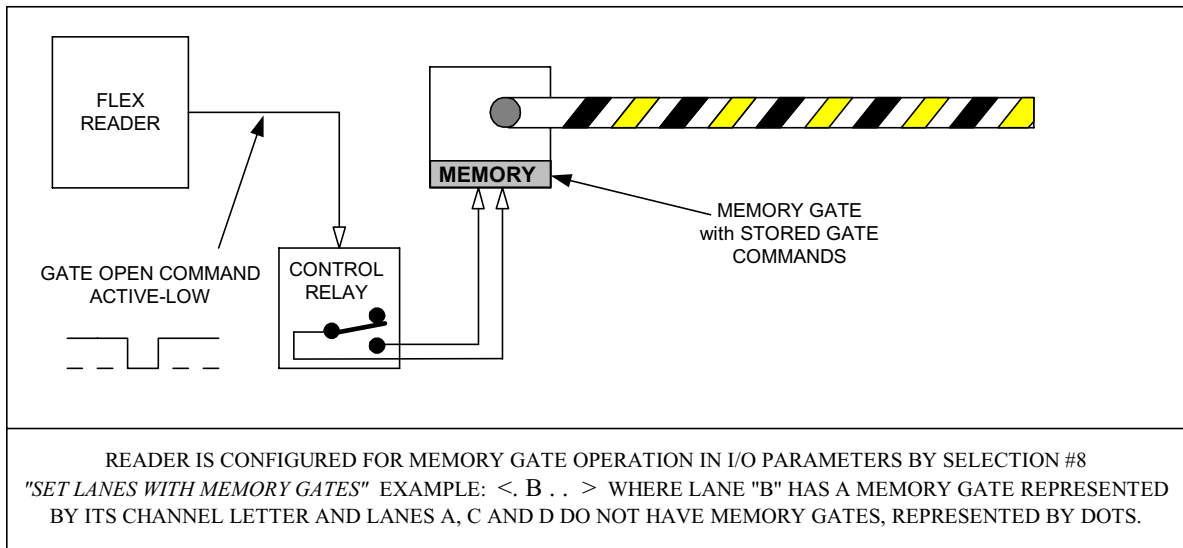

Figure 3.20 – Memory Lift Gate Operation

## POLLING SEQUENCES AND INDICATOR LIGHTS

The following table describes the indicating LEDs found on the reader. Under normal on-line operation, all of the indicating functions below are typical. However, under diagnostic “TEST HARDWARE” operation, the indicating functions completely change to indicate diagnostic and test results.

For example the ANT “A” LED which illuminates to indicate a good tag read under normal operation, will also illuminate under “TEST HARDWARE” operations when selection #4 is invoked to “Trigger ABCD Gate Outputs”. In this case the channel “A” LED flash indicates that the channel “A” discrete output circuit was pulsed, allowing one to test his associated relay or other device on that channel. **Be aware that most “Test Hardware” functions will take the reader Off-Line for the duration of the test.** Refer to the Diagnostics section starting on page 56.

Table 3.10 – Indicator LEDs

LED	LED Description
Port A (1)	<p>During normal operation, continuous illumination indicates when tag is being read by Port A of the reader system.</p> <p>During test operation, used to indicate condition of discrete inputs</p>
Port B (2)	<p>During normal operation, continuous illumination indicates when tag is being read by Port B of the reader system.</p> <p>During test operation, used to indicate condition of discrete inputs</p>
Port C (3)	<p>During normal operation, continuous illumination indicates when tag is being read by Port C of the reader system.</p> <p>During test operation, used to indicate condition of discrete inputs</p>
Port D (4)	<p>During normal operation, continuous illumination indicates when tag is being read by Port D of the reader system.</p> <p>During test operation, used to indicate condition of discrete inputs</p>
Tag Read (5)	<p>Indicates when information is being sent to the Host System by the Reader System. Flashes for one second when tag information has passed all internal filters and is sent on to the host system.</p>
Host RCV (6)	<p>Indicates when information is being received by the reader from the host system</p>
Sync Indicator (7)	<p>On=Master, Off=No Sync/Searching for sync, Flashing = Slave</p>
CPU Active (8)	<p>Flashing indicates that the Central Processing Unit is functioning</p>

# 4. Transponder Usage

## Metal-Oxide in Windshields

Metal Oxide is commonly used as a tinting agent in windshield glass. Some vehicle models equipped with metal-oxide windshields can decrease the transmission of radio frequency (RF) energy through the glass and may inhibit or affect the performance of such devices as cell phones, garage door openers and in-vehicle transponders. Metal-oxide windshields can affect any RF transmission.

Should the transponder be affected by the metal-oxide windshields, SIRIT recommends either relocating the internal transponder or utilizing its exterior-mounted license plate transponders that are unaffected by windshield content. Both interior (*IDentity Flex*) and exterior (T-21 readable) transponders are available from SIRIT.

## Transponder Testing

SIRIT recommends that **prior to affixing the transponder** to the windshield, that resellers/users test the transponder to determine if the windshield contains metal-oxides by following these steps:



- Hold the transponder by hand on the **inside** of the windshield in the position and orientation shown in the mounting instructions.
- Drive the vehicle through the appropriate lane under the antenna.
- A good read will be indicated by the gate opening or the antenna LED illuminating (if this option is installed). If the system registers a good read then your vehicle's windshield does not contain RF-inhibiting content and you can proceed with transponder mounting as described in the mounting instruction sheet.
- If the system does not read your transponder (the gate does not open or the antenna LED does not illuminate), then your vehicle's windshield may contain metal-oxide and **the transponder should not be mounted** to the windshield.
- To confirm that the metal-oxide windshield was the reason the system did not read the transponder, hold the transponder outside the vehicle, overhead, on the driver's side, in the orientation shown on the mounting instructions. Drive through the lane under the SIRIT antenna. If the gate opens, the windshield most likely contains metal-oxide or other RF-inhibiting material.
- Users should contact their reseller/administration who will locate another windshield location or replace the transponder with an exterior-mount license plate transponder.



# Transponder Mounting

## IDENTITY FLEX & S-FLEX TRANSPONDER

Follow the mounting instructions on the card attached to the transponder :

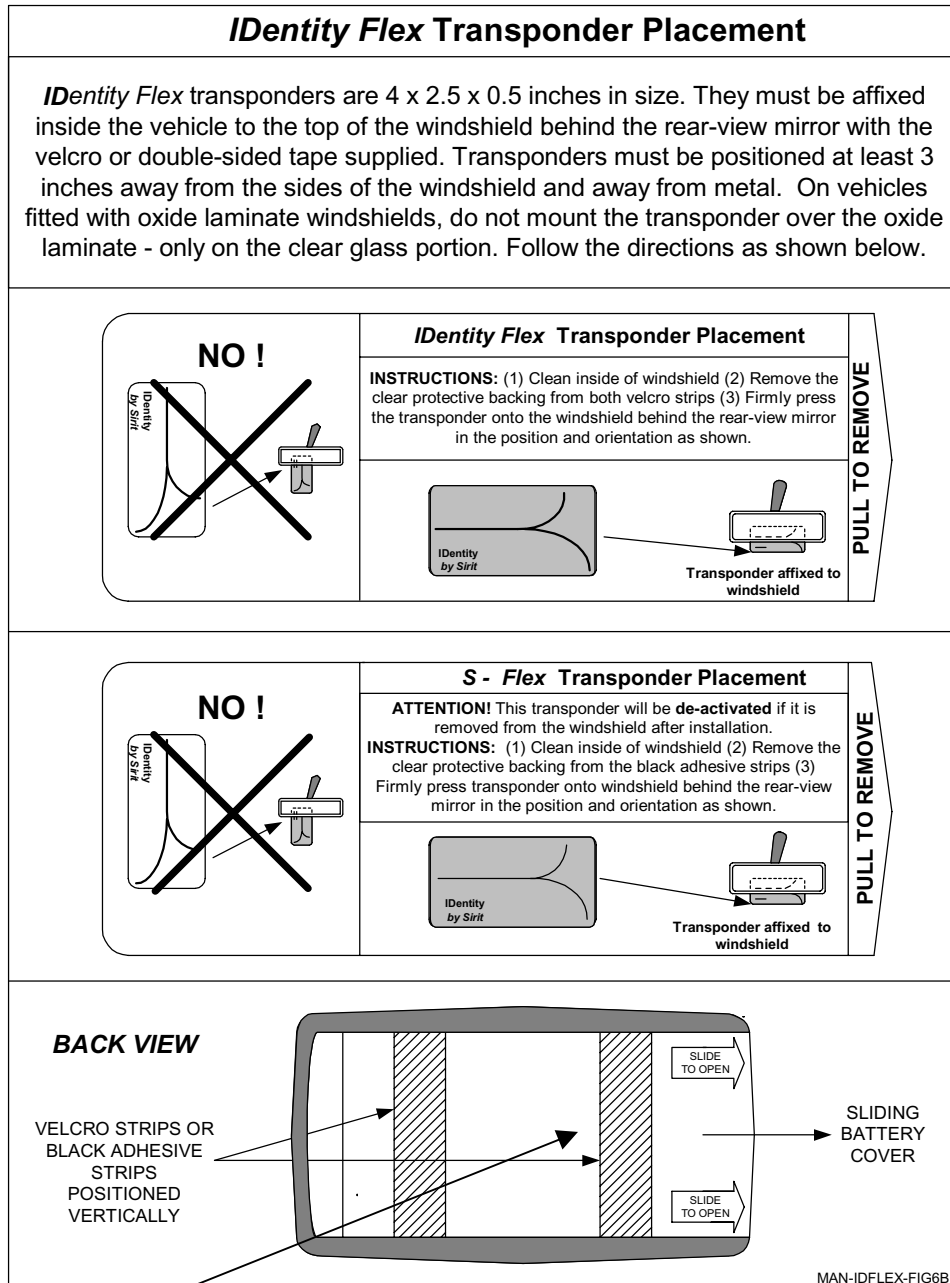

**\*\*Placement for SFlex adhesive is similar (utilizes 3 pieces of adhesive) PLEASE ENSURE WINDSHIELD IS CLEAN AND FREE OF DIRT.**

Figure 4.1 – Identity Flex Transponder Installation

## EXTERNAL MOUNT TRANSPONDER

Follow the mounting instructions below for the external mount transponder.

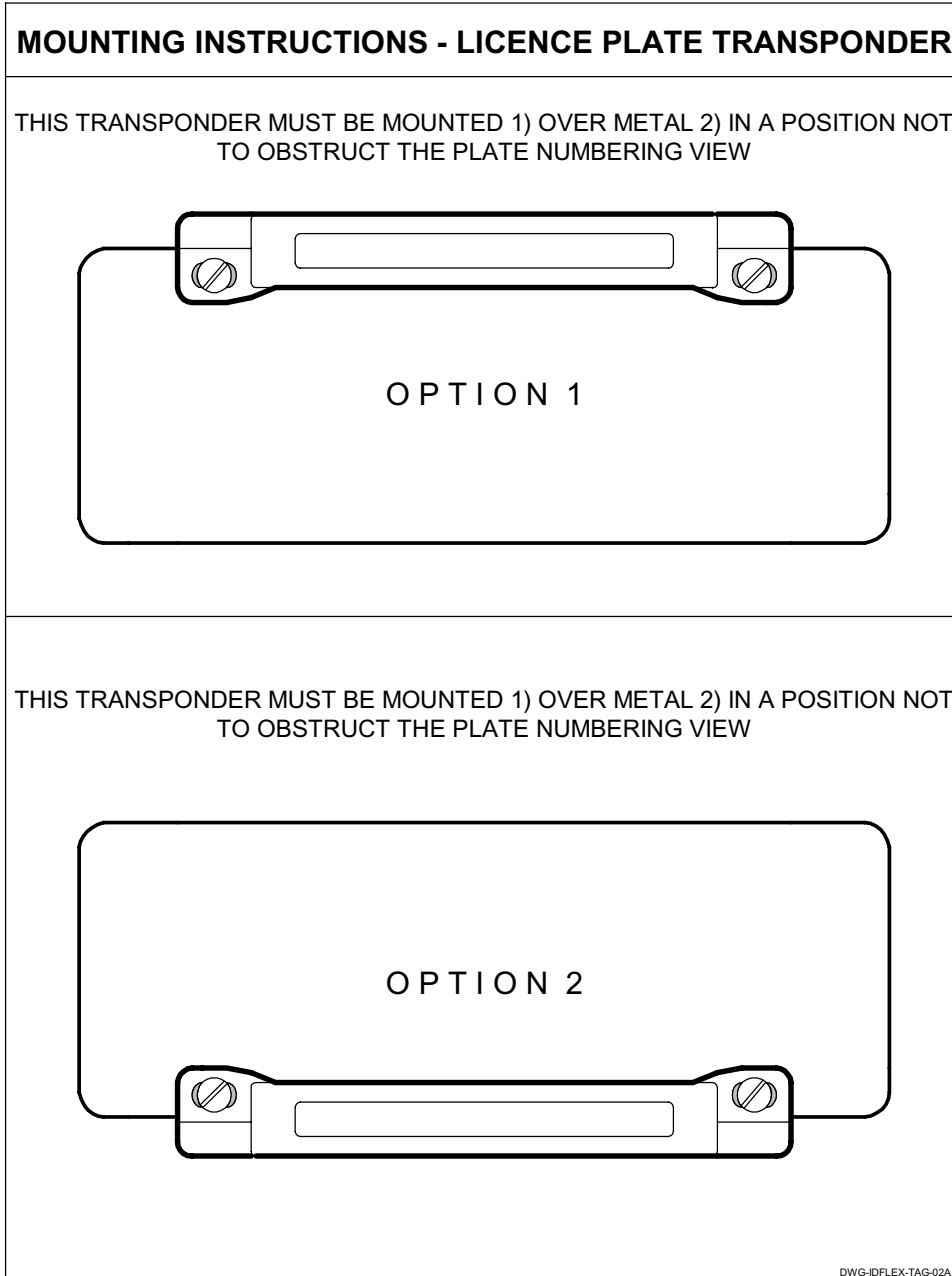

Figure 4.2 – External Mount Transponder Installation

# IDENTITY TITLE 21 TOLLING APPLICATION TRANSPONDER

Follow the mounting instructions below for the Title 21 transponder.

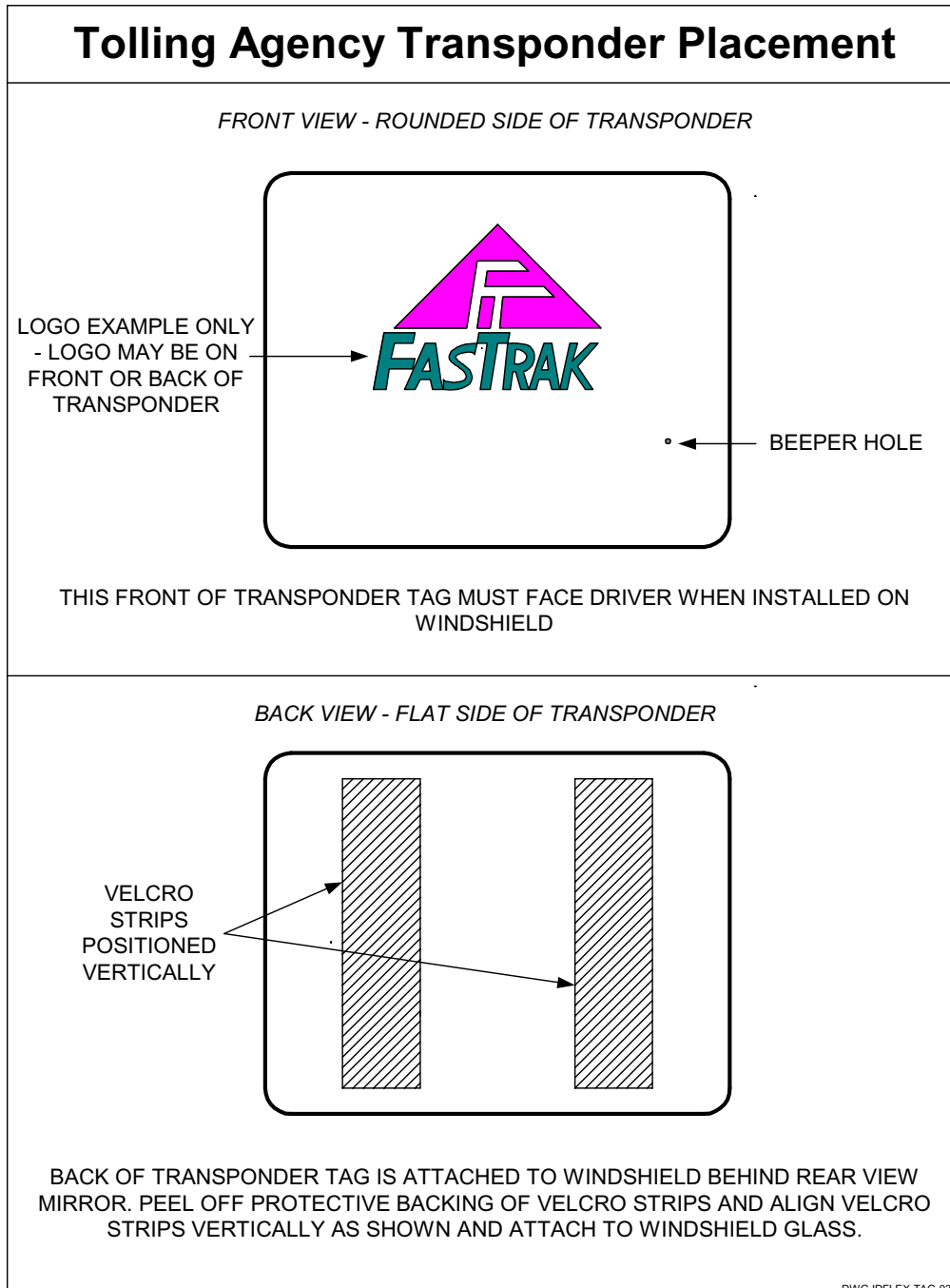

Figure 4.3 – Title 21 Transponder Installation

## Conversion Procedure for T21 Transponders

This conversion procedure is utilized by SIRIT's DOS-based software to allow Title 21 (T21) transponders to be read by the *IDentity Flex* system. Since the *IDentity Flex* Reader requires each transponder ID to be in hexadecimal format they must first be converted to hex and then entered via the conversion utility, which will update the tag list file.

- 1.) Boot up the reader and select menu option “**3 - Tag List Maintenance**”. <3> <ENTER>
- 2.) From the Tag List menu select menu option “**6 – Manually Add Tag to Update List**”. <6> <ENTER>
- 3.) Select menu option “**T**” for a T21 type transponder. <T> <ENTER>
- 4.) At the screen option “**Enter Search ID in HEX**” – Enter the 8-digit number shown on the transponder’s label and <ENTER>. Another way to find this number is to have the system read the tag and then record the number that comes up on the screen.
- 5.) At the screen option see “**Enter Translate ID in HEX**”. This is the number that the customer will assign to that tag. This number must be entered in hexadecimal format so the facility code/ID or Group#/System Code/ID will need to be converted into HEX first. See example below. Input the 8-digit number and <ENTER>.
  - **Example:**
  - Customers Facility Code in decimal: **Facility Code 200**
  - Customers desired transponder Number in decimal: **Tag # 1201**
  - **200** in decimal is **00C8** in hexadecimal
  - **1201** in decimal is **04B1** in hexadecimal
  - Put both hex numbers together (FC plus Tag#) to create the following hexadecimal number: **00C804B1**
  - Type the 8-digit hexadecimal number into the “**Translate ID in Hex**” field.
- 6.) At the screen option “**Tag Status (ALLOW or BLOCK [A/b])**” select “**A**” to **ALLOW** tag access and <ENTER>
- 7.) Select “**X**” to exit from the program, then “**Y**” to save changes.

## Adding External Mount Transponders to the Tag List

Note that the external-mount license plate transponder is a T-21 type and is not an *IDentity Flex* transponder. Therefore any of the T-21 transponders so issued will need to be coded into the TAG MAINTENANCE LIST via the maintenance port with a lap-top or PC since T-21 tags function differently using hex ID's.

To add external-mount transponders to the tag list, follow the same procedure for converting Title 21 tags, detailed above.

# 5. Diagnostics & Troubleshooting

This section is intended to help you identify and correct some common problems that can occur. For additional information or assistance with any query, please call SIRIT at 1-877-492-0101ext. 2550.

## Diagnostic Features

The *IDentity Flex* reader possesses extensive diagnostic testing features which are initiated and manipulated by the maintenance computer. The testing features include:

1. Echo ABCD Loop Inputs to LEDS
2. Echo ABCD Gate Inputs to LEDS
3. Trigger ABCD Lamp Outputs
4. Trigger ABCD Gate Outputs
5. Read Tags and Display Results
6. Test Host Serial Port
7. Test Wiegand Port
8. Test SYNC Port
9. Test Static RF Power
10. Test RF Noise Detection

When the reader system is commanded to perform test mode operations, normal reader functions are suspended and under menu options 1, 2, 3 or 4, the ANT A, ANT B, ANT C and ANT D indicator LEDS become Discrete I/O Indicator lights.

### PERFORMING TESTS UTILIZING MENU OPTIONS 1 OR 2

Menu options 1 or 2 allow testing of all discrete inputs (Loops and Gates). Logic conditions of the discrete inputs are reflected upon the ANT A, B, C and D indicator lights. For example, utilizing menu option #1, "ECHO ABCD LOOP INPUTS TO LEDS", if the ABCD Loop Inputs are configured for active-low inputs and there are no signal lines connected to the input connector, the inputs are floating high and therefore the ANT A, B, C and D indicator lights will be off. Any of the inputs that are then connected to a ground or see the normally-open contacts of a relay go closed will be simulating an active-low input signal and will cause the associated indicator light to illuminate.

Conversely if the Loop Input is configured for active-high operation, the inputs will likely be at ground potential due to being connected to the closed contacts of a relay or device somewhere. When those contacts open due to some system activity, the reader’s pull-up resistor momentarily pulls that input voltage up and that will cause the associated LED to illuminate.

## PERFORMING TESTS UTILIZING MENU OPTIONS 3 OR 4

Menu options 3 or 4 allow testing of all discrete outputs (Lamps and Gates). When one of these options is selected, the discrete output may be triggered by command from the maintenance computer keyboard. The antenna A, B, C or D indicator light will illuminate when a specific discrete output is commanded. An output pulse that conforms to the menu configured polarity, pulse width, hold-off settings and at a voltage level of 5 or 12 VDC as determined by installed jumpers will be generated at the discrete output connector.

# Troubleshooting

## COMMON PROBLEMS AND SOLUTIONS

**Problem No. 1: No power**  
 Indicator: No lights on board (in particular CPU ALIVE or flashing SYNC)

Checklist	Solutions	Reference
Check incoming voltage at power terminal trip. Should be 120 VAC.	Correct problem with 120 VAC supply. Reset circuit breaker or replace AC line fuses at panel.	p. 19 p. 24 p. 34
Check DC Power Supply voltages on Flex reader terminals. See Figure 3.4 for DC voltages.	If incorrect or no DC output voltages found replace DC power supply module.	Figure 3.5 p. 26
Check AC line fuses in power supply.	Replace AC line fuses in DC power supply. Measure voltages.	p. 24
Check power cabling for damage.	With AC power disconnected replace defective wiring.	p. 19

**Problem No. 2: Transponders do not read**

Indicator: Holding a transponder in front of antenna, channel lamp/tag read lamp does not light up

Checklist	Solutions	Reference
Check that 120 VAC power is available. Check that DC Power Supply functions properly and outputs correct DC voltages.	Restore AC power or replace DC power supply.	See section above
Check reader for loose RF connectors.	Make sure RF connectors are tight.	p. 18
Check antenna for loose RF connectors.	Make sure connectors are tight and that waterproofing is in place.	p. 18
Check reader RF output level.	Check software settings. Connect RF wattmeter and 50-ohm load to reader. There should be 1-watt output with a software setting of 250. Set to correct RF level.	See software manual
If an RF cable test set is available (example Bird AT-800) check antenna system VSWR. VSWR should be 1.1 or less.	With the Flex reader OFF, connect coaxial cable test set.	Use cable test set
Check for shorts or opens in coaxial cables.	If broken or bare wire exposed, replace cable. Test with ohmmeter. Test with coaxial cable test set or reflectometer.	Use DMM Use cable test set
If there is more than one reader, check synchronization.	Make proper connections as per section on reader synchronization.	p. 41
Check configuration of arming loop.	Check software settings to determine whether arming loop is enabled or disabled	See software manual
Check operation of arming loop	Make sure proper signals are being received at reader.	
Measure RF output power	A directional Wattmeter or Rel. DB meter is required.	Contact SIRIT for more information

**Problem No. 3: Poor or reduced read range**

Indicator: Holding a transponder in front of antenna, maximum read range is less than 3 or 4 feet, or transponders read intermittently

Checklist	Solutions	Reference
Check for faulty cable connection or break in cable	Using an Ohm meter, verify that the outer shield and inner conductor are not shorted. Once this is verified, short one end of the cable, using the Ohm meter again, check to ensure no breaks in the cable. Observe the center pin in the N connector to ensure it is not recessed and well seated.	
Check sync pulse	Ensure sync pulse is present	
Check reader software configuration	Ensure that RF power settings for Flex and T21 Uplink and Downlink are set properly.	See software manual
Check that the correct coaxial cable is in use for the distance covered between reader and antenna.	Ensure that excessively lossy cable is not in use, for example using RG-58/U to reach 100 feet away. Refer to Table 2.1 for cable distances permitted	p. 8 p. 17 p. 27
Check windshield for metal oxide.	If windshield contains metal oxide replace transponder with external license plate transponder, otherwise consult with vehicle manufacturer for correct location for internal transponders.	p. 51
Check mounting orientation of transponder on windshield.	Rotate or re-position transponder and re-mount according to proper mounting instructions.	p. 52
Check orientation of antennas. Antennas should beam down onto the windshield from above, not sideways across the windshield from the side.	Re-adjust antenna to correct position beaming down onto windshield. Ensure that antenna is not beaming across the lane at a 90-degree angle.	p. 7 p. 20 p. 22 p. 22
Check reader for loose RF connectors.	Make sure RF connectors are tight.	p. 18

Checklist	Solutions	Reference
Check antennas for loose RF connectors.	Make sure RF connectors are tight and waterproofing is in place.	p. 18
Check for large metal objects in front of antenna that can reflect signals.	Move antenna location so reflections can be eliminated or reduced.	p. 16
Check the antennas' proximity to one another; an antenna should not be beaming right into another antenna at close range. Check site layout plan.	Move antenna locations so that antennas are behind each other, minimizing the possibility of reflections from an antenna.	p. 23
Check the coaxial cables for shorts or opens or poor condition.	Use ohmmeter to test for shorts or opens. Use Cable Test Set to measure RF condition of cable.	p. 18 Use cable test set
Check synchronization between multiple reader systems.	Make proper connections and ensure sync jumpers are correct. Use oscilloscope to observe and measure 8-volt sync pulse train.	p. 41

**Problem No. 4: Reader will not communicate through the host serial port or maintenance port.**

Indicator: Transponders are being read properly but no data is being received through the host serial port; unable to access reader menus, via the maintenance port.

Checklist	Solutions	Reference
Check that the RS-232 cable between reader's maintenance port and PC is a Serial Pin-to-Pin Cable.	If a Null-Modem cable is being used replace cable with Serial Pin-to-Pin cable.	p. 19
Check host serial port configuration.	Set Host serial port configuration to <b>9600 Baud, 8 Data Bits, no Parity, 1 Stop Bit, no Hardware</b>	p. 36 See software manual
Check host port jumpers.	Ensure that RS-232 is configured at the host port jumpers and not some other protocol such as RS-485 or RS-422.	p. 36 p. 38

Check serial cable connections.	Reverse the TX-RX pair and check that the ground is good.	p. 35
---------------------------------	---	-------

**Problem No. 5: Reader will not communicate through Wiegand ports**  
 Indicator: Transponders are being read properly but no Wiegand data is being received through the Wiegand port

Checklist	Solutions	Reference
Check Wiegand jumpers at JP1 and JP2	Verify that correct jumpers are in.	p. 38
Check Wiegand Interface at host PC	Verify that Wiegand transponder format matches the reader configuration, i.e. 26-bit reader configured to read 26-bit transponders	See software manual
Check Wiegand Interface connections	Connect to correct terminals	p. 38
Check data and ground connections	Verify and secure connections	p. 38

**Problem No. 6: Reader will not activate relay or incorrect relay activates**  
 Indicator: Transponders are being read properly but the relay will not activate or the wrong relay activates.

Checklist	Solutions	Reference
Check jumper settings.	Verify that all jumpers are inserted correctly, 5 volt jumpers IN for 5 volt relays, 12 volt jumpers IN for 12 volt relays, etc.	p. 44
Check all relay connections.	Make proper relay connections.	p. 44 p. 43
Check relay fuses in solid state relays	Replace bad relay fuse.	Check relay fuses
Check ground connections.	Verify and secure connections.	N/A
Check/Inspect relay interface cable	Test cable for shorts or opens	N/A
Check main fuse on relay board	Replace bad fuse	
Verify +5 volts on relay signal	Contact SIRIT for service	

**Problem No. 7 Reader will not function or is frozen or locked up**  
 Indicator: Power/CPU-Alive indicator is on but CPU may be locked up

Checklist	Solutions	Reference
Check that reader has power	Measure voltages at DC power terminals	p. 26
Check RESET button	Push RESET button located in a small hole beside CPU lamp for 1 second and reader will re-boot. RESET button has the same function as the power ON/OFF switch	p. 34
If reader is hot, power down and allow reader to cool down for 15-20 minutes.	Re-apply power and test for functionality	N/A

# 6. Components, Accessories and Options

## IDentity Flex Component Part Numbers

Table 6.1 – IDentity Flex Component Part Numbers

Customer Part Number	Description
IDFLEX-TAG-4	4Year IDentity Flex transponder tags
IDFLEX-TAG-4WBOR	4Year IDentity Flex transponder (with BOR)
IDFLEX-TAG-4LP	IDentity Flex License Plate Mount transponder
IDFLEX-BAT-CLIP	Additional 4-Year battery and clip for IDentity Flex tags (excludes IDFLEX-TAG-4LP)
IDFLEX-VELCRO	Velcro Strips for IDentity Flex tags
IDFLEX-TS-TAPE	Tape strips for IDentity Flex tags
IDFLEX-READER-IIe	Two-Channel IDentity Flex reader with NEMA enclosure.
IDFLEX-READER-IVe	Four-Channel IDentity Flex reader with NEMA Enclosure.
IDFLEX-ANT-01	IDentity Flex 12" x 30" antenna with universal mounting bracket, includes hardware for a 1-1/2" pole
IDFLEX-CB-II	2-Channel IDentity Flex transceiver unit
IDFLEX-CB-IV	4-Channel IDentity Flex transceiver unit.
IDFLEX-READER-PS	IDentity Flex power supply
IDFLEX-MAN-S/W (DOS Version)	IDentity Flex Software and Configuration Guide for DOS
IDFLEX-MAN-S/W (WINDOWS® Version)	IDentity Flex Software and Configuration Guide for WINDOWS®
IDFLEX-MAN-H/W	IDentity Flex Hardware Installation and Troubleshooting Guide

## Options and Accessories

Table 6.2 – Options and Accessories Part Numbers

Part Number	Description
<b>IDFLEX-ANT-CMB</b>	Universal ceiling mount antenna bracket, Includes U-bolts for a 1-1/2" pole
<b>IDFLEX-ANT-WMB</b>	Universal pole/wall mount antenna bracket
<b>IDFLEX-CONN-RG-58/U</b>	Connector kit for RG-58/U Qty. 2 per kit – Amphenol 82-5375 Qty. 2 per kit – AMP 226600-1
<b>IDFLEX-CONN-9913</b>	Connector kit for 9913 cable Qty. 4 per kit – Amphenol 82-202-1006
<b>IDFLEX-CABLECON</b>	Cable adapter kit – adapts Belden 9913 cable Type N connector to Mini-UHF connector. Includes 18" of cable, Type N Male to Mini-UHF Male, with Jack-to-Jack Type N thru-barrel. Qty. 2 per kit
<b>IDFLEX-CRIMP</b>	Cable crimp tool for Amphenol 82-5375 and AMP 226600-1 connectors
<b>IDFLEX-CONN-WKIT</b>	Outside weather-proofing kit: Qty. 1 – piece mastic tape, Qty. 1 electrical tape, for 1 outside antenna connectors
<b>IDFLEX-CABLE-RG58/U-60K</b>	2 ea 50' RG-58/U Cable, N connector attached, 2 mini UHF Connector assembly included
<b>For Relays and Relay Options, please contact SIRIT</b>	
<b>RELAY AC/DC INPUT MODULE</b>	3-30 VDC or 10-60 VAC from source
<b>DRY CONTACT RELAY MODULE</b>	Dry contact relay
<b>CABLE ASSEMBLY FOR 2-4 MODULE RELAY BOARDS</b>	DB-37 connector mates with J5 on reader I/O connector.
<b>4-MODULE RELAY BOARD</b>	4-Relay mounting circuit board
<b>16-MODULE RELAY BOARD</b>	16-Relay mounting circuit board

## Opto-Isolated Relay Wiring Guide

The following wiring guide will assist the installer in wiring opto-isolated relays. The four-module boards are detailed below, and the sixteen-module board section starts on page 67.

**Table 6.3 – Four-Module Board Input Specification**

Relay Board Input Control Terminals	Signal Function	Notes
1	VCC +5 VDC Input	Orange
2	Ground Input from Reader Discrete I/O Cable	Green / White
3	Relay Module #1 Control Signal (Active Low)	
4	Ground	No Connection required
5	Relay Module #2 Control Signal (Active Low)	
6	Ground	No Connection required
7	Relay Module #3 Control Signal (Active Low)	
8	Ground	No Connection required
9	Relay Module #4 Control Signal (Active Low)	

**Table 6.4 – Four-Module Board Output Specification**

Relay Board Output Terminals	Signal Function
1	Relay Module #1 (+)
2	Relay Module #1 (-)
3	Relay Module #2 (+)
4	Relay Module #2 (-)
5	Relay Module #3 (+)
6	Relay Module #3 (-)
7	Relay Module #4 (+)
8	Relay Module #4 (-)

Note: The Relay Board Output Terminals are labeled as Relay Module (+) and Relay Module (-). This convention refers to the direction of the current flow from the peripheral being controlled. Refer to attached schematic example for Relay Module #1

Table 6.5 – Discrete I/O Cable

SIRIT P/N: 9796157-0002		
Cable Conductor Color	37 Pin Connector Pin Number	Discrete Output and Input Function
Black	1	Lamp Output Channel A
White	2	Lamp Output Channel B
Red	3	Lamp Output Channel C
Green	4	Lamp Output Channel D
Red/Green	20	Gate Output Channel A
Orange/Green	21	Gate Output Channel B
Black/White/Red	22	Gate Output Channel C
White/Black/Red	23	Gate Output Channel D
Black/Red/Green	28	Entrance Loop Input Channel A
White/Red/Green	29	Entrance Loop Input Channel B
Red/Black/Green	30	Entrance Loop Input Channel C
Green/Black/Orange	31	Entrance Loop Input Channel D
Orange/Black	10	Gate Position Channel A
Blue/Black	11	Gate Position Channel B
Black/White	12	Gate Position Channel C
Red/White	13	Gate Position Channel D
Orange	5	VCC +5VDC
Blue	6	VCC +5VDC
White/Black	7	VCC +5VDC
Red/Black	8	VCC +5VDC
Green/Black	9	VCC +5VDC
Red/Black/White	24	VCC +5VDC
Green/Black/White	25	VCC +5VDC
Orange/Black/White	26	VCC +5VDC
Blue/Black/White	27	VCC +5VDC
Green/White	14	GND
Blue/White	15	GND
Black/Red	16	GND
White/Red	17	GND
Orange/Red	18	GND
Blue/Red	19	GND
Orange/Black/Green	32	GND

Blue/White/Orange	33	GND
Black/White/Orange	34	GND
White/Red/Orange	35	GND
Orange/White/Blue	36	GND
White/Red/Blue	37	GND

**Table 6.6 - Sixteen- Module Board Input Specification**

<b>Relay Board Input Control Terminals</b>	<b>Signal Function</b>	<b>Notes</b>
+V	VCC +5 VDC Input	Orange
GND	Ground Input from Reader Discrete I/O Cable	Green / White
1	Ground	No Connection Required
2	Relay Module #1 Control Signal (Active Low)	
3	Ground	No Connection Required
4	Relay Module #2 Control Signal (Active Low)	
5	Ground	No Connection Required
6	Relay Module #3 Control Signal (Active Low)	
7	Ground	No Connection Required
8	Relay Module #4 Control Signal (Active Low)	
9	Ground	No Connection Required
10	Relay Module #5 Control Signal (Active Low)	
11	Ground	No Connection Required
12	Relay Module #6 Control Signal (Active Low)	
13	Ground	No Connection Required
14	Relay Module #7 Control Signal (Active Low)	
15	Ground	No Connection Required
16	Relay Module #8 Control Signal (Active Low)	
17	Ground	No Connection Required
18	Relay Module #9 Control Signal (Active Low)	
19	Ground	No Connection Required
20	Relay Module #10 Control Signal (Active Low)	
21	Ground	No Connection Required
22	Relay Module #11 Control Signal (Active Low)	
23	Ground	No Connection Required
24	Relay Module #12 Control Signal (Active Low)	
25	Ground	No Connection Required
26	Relay Module #13 Control Signal (Active Low)	
27	Ground	No Connection Required
28	Relay Module #14 Control Signal (Active Low)	
29	Ground	No Connection Required
30	Relay Module #15 Control Signal (Active Low)	
31	Ground	No Connection Required
32	Relay Module #16 Control Signal (Active Low)	

**Table 6.7 - Sixteen-Module Board Output Specification**

<b>Relay Board Output Terminals</b>	<b>Signal Function</b>
1	Relay Module #1 (+)
2	Relay Module #1 (-)
3	Relay Module #2 (+)
4	Relay Module #2 (-)
5	Relay Module #3 (+)
6	Relay Module #3 (-)
7	Relay Module #4 (+)
8	Relay Module #4 (-)
9	Relay Module #5 (+)
10	Relay Module #5 (-)
11	Relay Module #6 (+)
12	Relay Module #6 (-)
13	Relay Module #7 (+)
14	Relay Module #7 (-)
15	Relay Module #8 (+)
16	Relay Module #8 (-)
17	Relay Module #9 (+)
18	Relay Module #9 (-)
19	Relay Module #10 (+)
20	Relay Module #10 (-)
21	Relay Module #11 (+)
22	Relay Module #11 (-)
23	Relay Module #12 (+)
24	Relay Module #12 (-)
25	Relay Module #13 (+)
26	Relay Module #13 (-)
27	Relay Module #14 (+)
28	Relay Module #14 (-)
29	Relay Module #15 (+)
30	Relay Module #15 (-)
31	Relay Module #16 (+)
32	Relay Module #16 (-)

**SIRIT P/N: 9796150-0002**

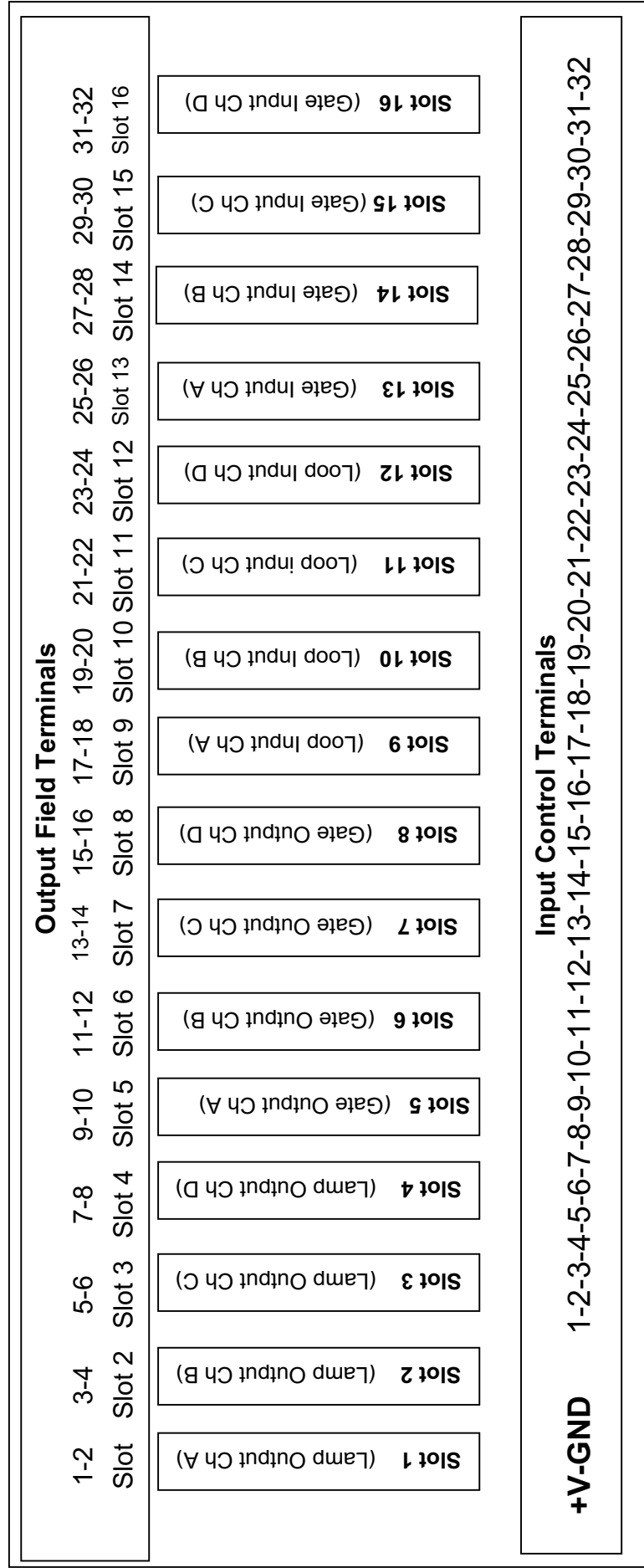

**Figure 6.1 – Sixteen-Module Board Terminals**

**Figure 6.2 - 4 Channel Relay Mother Boards**

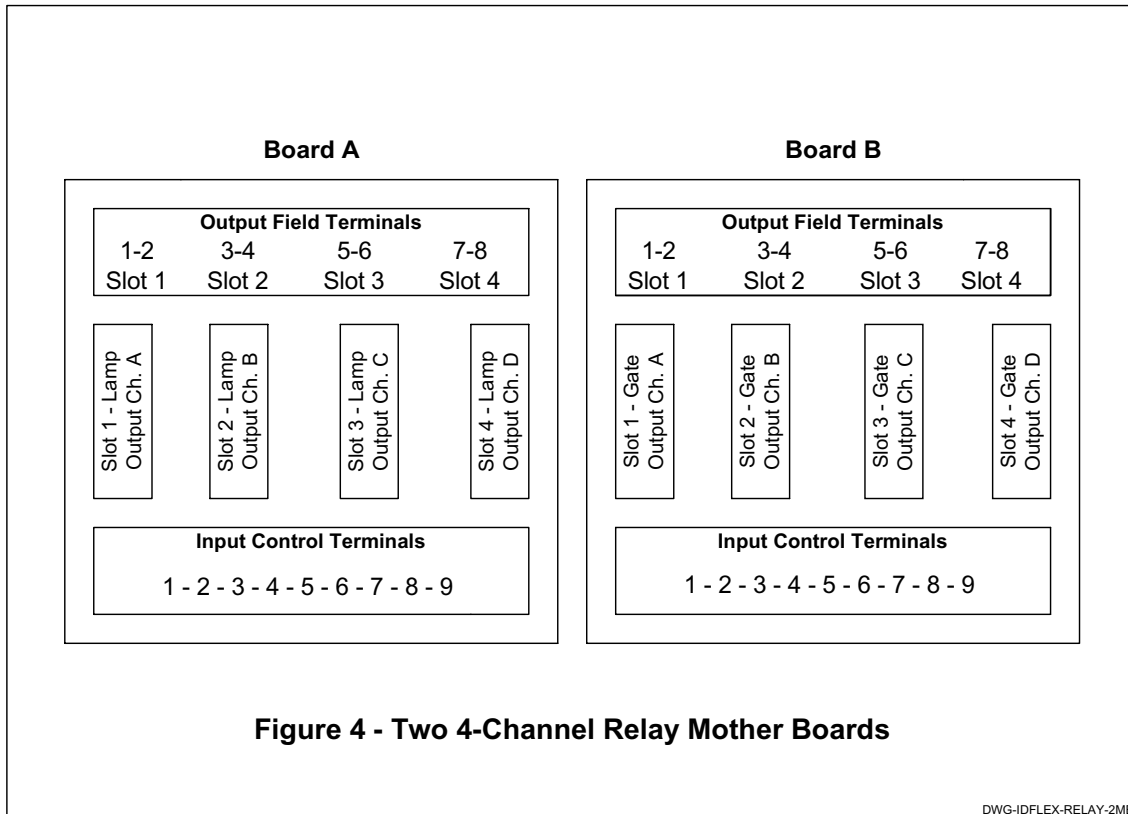

# 7. Component Specifications

## Reader System

### Environmental

Storage Temperature:	-40°C to +60°C
Operating Temperature:	-25°C to +60°C
Humidity:	85% non-condensing at 85°C
Vibration:	1g at 15 Hz to 500 Hz
Shock:	5g at 10 ms

### Enclosure

Enclosure:	NEMA 4X enclosure
Enclosure dimensions:	16" x 14" x 9"
Weight:	7.8 pounds

### Transceiver Specifications

Dimensions:	9.5" x 9" x 1"
Weight:	2.5 pounds
Input Impedance:	50 Ohms
Output Impedance:	50 Ohms
Output Power:	33 dBm (2W)
Down-link Modulation:	T21 AM, Manchester encoded, 300 Kbps
Up-link Modulation:	T21 Frequency shift Keyed, 300 Kbps 2PSK Two Phase Shift Keyed, 150 Kbps
Operating Frequency:	916.25 MHz
DC Power requirements:	+12 +/- 0.5 VDC @ 3.5 Ampere -12 +/- 1 VDC @ 1.0 Ampere +5 +/- 0.25 VDC @ 1.0 Ampere
Max. continuous power consumption:	20 Watts
Standards:	Reads Caltrans Title 21 compliant transponders FCC Part 15 Approved FCC Part 90 Approved FCC ID JNB9796254 Industry Canada Type Approval No. 3637371115A

### Power Supply Dimensions:

Weight:	11.75" x 5" x 3"
AC Power Input:	5 pounds
	85-264 VAC, 47-93 Hz, 4A

# Antenna

## ***FLEX ANTENNA***

### **Dimensions**

Dimensions:	30"x 12"x 1.5"
Weight:	7.8 pounds

### **Specifications**

Input Impedance:	50 Ohms
Output Impedance:	50 Ohms
Frequency:	916.25 MHz
VSWR:	< 1.5 in band

## ***UNIVERSAL MOUNTING BRACKET***

### **Dimensions**

Dimensions:	4" x 4" x 4"
Weight:	1.1 pounds

# Transponder

### **Environmental**

Storage Temperature:	-40°C to 100°C
Operating Temperature:	-25°C to +85°C
Humidity:	85% non-condensing at 85°C
Vibration:	10g, ½ Sine pulse 10ms duration
Shock:	5g, ½ Sine pulse 10ms duration

## ***IDENTITY FLEX AND S-FLEX TRANSPONDER***

### **Enclosure**

Enclosure:	Polycarbonate weather-resistant plastic
Dimensions (WxHxD):	4.2" x 2.6" x 0.5"
Weight:	2.2 Ounces

## Specifications

Uplink Modulation:	2PSK Two Phase Shift Keyed (150 Kbps)
Operating Frequency:	916.25 MHz
Data Storage:	32 bit transponder ID
Battery Requirements:	3.0 Volts ( non-replaceable cell - replaceable CR2032 cell with Flex only ) One cell yields a transponder life of up to 4 years
Read Range:	Up to 25 feet, set by reader and antenna configuration, cabling length and power output

## **EXTERNAL LICENSE PLATE TRANSPONDER**

### Environmental

Storage Temperature:	-40C to 114C
Operating Temperature:	-25C to +85C
Humidity:	95% non-condensing at 70°C
Vibration:	10g, ½ Sine pulse 10ms duration
Shock:	5g, ½ Sine pulse 10ms duration

### Enclosure

Enclosure:	Polycarbonate weather-resistant plastic
Dimensions (WxHxD):	4.2" x 2.6" x 0.5"
Weight:	2.2 Ounces

## Specifications

Uplink Modulation:	2PSK Two Phase Shift Keyed (150 Kbps)
Operating Frequency:	916.25 MHz
Data Storage:	32 bit transponder ID
Battery Requirements:	3.0 Volts (non-replaceable cell) One cell yields a transponder life of up to 4 years
Read Range:	Up to 25 feet, set by reader and antenna configuration, cabling length and power output

# 8. Reference

## Glossary

AC	Alternating Current
AM	Amplitude Modulation
AVI	Automatic Vehicle Identification
BIN	Binary
BOR	Break on Removal
CRT	Cathode Ray Tube - display
COM	Communications
CWB	Concrete Wall/Pole Bracket, optional mounting pipe with bracket
dB	decibel – level of a signal
dBm	decibels referenced to one milliwatt of power
DC	Direct Current
DC	Dealer Code
FC	Facility Code
FCID	Facility Code Identification
FCC	Federal Communications Commission – a regulatory agency
FM	Frequency Modulation
IL	Issue Level
I/O	Input / Output – data doorway to and from a device
KHz	Kilohertz – 1,000 cycles per second
Kbps	Kilo Bits per Second
mA	Milliampere
Mbps	Mega Bits per Second
MHz	Megahertz – 1,000,000 cycles per second
ms	Millisecond
NEMA	National Electrical Manufacturers Association
PSK	Phase Shift Keying
2PSK	Double Phase Shift Keying
RF	Radio Frequency (radio frequency energy)
RFID	Radio Frequency Identification
RX	Receive
RXd	Received Data
SYNC	Synchronization Signal
TTL	Transistor-Transistor Logic – logic circuits
TX	Transmit
TXd	Transmitted Data
T21	Title 21 (California tolling system)
UHF	Ultra High Frequency
UMB	Universal Mounting Bracket supplied with Flex antenna
VAC	Voltage – Alternating Current
VDC	Voltage – Direct Current
VSWR	Voltage Standing Wave Ratio
WIEGAND	26, 34 or 50-bit binary-encoded data used in the control industry

# List of Figures

Figure 1.1 – System Operation.....	2
Figure 1.2 – <i>IDentity Flex</i> Mounting Options .....	7
Figure 2.1 – Typical Parking Access Lane Configuration .....	11
Figure 2.2 – Typical Gated Access Lane Configuration .....	13
Figure 3.1 – Antenna Orientation .....	20
Figure 3.2 – Antenna Mounting Angles .....	22
Figure 3.3 - Antenna Lateral Orientation .....	23
Figure 3.4 – Remote Antenna/Reader Connection Diagram .....	24
Figure 3.5 – Reader Connections.....	26
Figure 3.6 – RG-58/U Amp 226600-1 Installation .....	29
Figure 3.7 – RG-58U Amphenol 82-5375 Installation (Part A).....	30
Figure 3.8 - RG-58U Amphenol 82-5375 Installation (Part B).....	31
Figure 3.9 – Belden 9913 Amphenol 82-202-1006 Installation .....	32
Figure 3.10 – Antenna Cable Adapter Connection.....	33
Figure 3.11 – <i>IDentity Flex</i> Reader Connections .....	34
Figure 3.12 – Host Interface Connector and Jumpers .....	36
Figure 3.13– Typical Internal Wiegand Pull-up Circuit .....	39
Figure 3.14 - Sync Pulse Characteristics .....	40
Figure 3.15 – Multiple Reader System Sync Connections .....	41
Figure 3.16 – Discrete Input/Output Jumpers .....	44
Figure 3.17 – Typical Input / Output Circuit and Pull- Up Resistors.....	45
Figure 3.18 – Examples of Active-High and Active-Low Polarities .....	45
Figure 3.19 – <i>IDentity Flex</i> Non-Memory Lift Gate Operation .....	48
Figure 3.20 – Memory Lift Gate Operation .....	49
Figure 4.1 – <i>IDentity Flex</i> Transponder Installation.....	52
Figure 4.2 – External Mount Transponder Installation .....	53
Figure 4.3 – Title 21 Transponder Installation .....	54
Figure 6.1 – Sixteen-Module Board Terminals.....	69
Figure 6.2 - 4 Channel Relay Mother Boards.....	70

# List of Tables

Table 2.1 – Remote Antenna Cable Selection .....	17
Table 2.2 – Antenna/Reader Connector Selection.....	18
Table 3.1 – Legend for Figure 3.4 .....	25
Table 3.2 – Maintenance Port Pin-outs .....	35
Table 3.3 – Emulation Settings.....	36
Table 3.4 – Host Interface Connector Pin Functions.....	36
Table 3.5 – Wiegand Interface Specifications .....	37
Table 3.6 – Wiegand Connector Pin-outs .....	38
Table 3.7 – Wiegand Jumper Port Layout.....	38
Table 3.8 – 37-Pin Discrete Input / Output Connector J5 .....	43
Table 3.9 – Jumper Pin-out and Function Table .....	44
Table 3.10 – Indicator LEDs .....	50
Table 6.1 – <i>IDentity Flex</i> Component Part Numbers.....	63
Table 6.2 – Options and Accessories Part Numbers .....	64
Table 6.3 – Four-Module Board Input Specification .....	65
Table 6.4 – Four-Module Board Output Specification .....	65
Table 6.5 – Discrete I/O Cable .....	66
Table 6.6 - Sixteen- Module Board Input Specification .....	67
Table 6.7 - Sixteen-Module Board Output Specification .....	68

# Index

- 37-pin discrete i/o connector.....43
- 4-mile limit..... 15
- AC or DC input relay module.....46
- AC power cabling.....17, 21
- AC power connections.....19
- accessories.....63
- adjacent lanes.....10, 41
- alternate studs.....25
- antenna
  - arming for parking access.....12
  - bracket.....25
  - cable adapter connection.....33
  - cable connectors.....18
  - cable selection.....17
  - description.....6
  - installation.....20
  - lateral orientation.....21
  - lead installation.....27
  - LED feature.....6
  - location.....6
  - mounting.....20
  - mounting brackets.....6
  - mounting for gated access.....15
  - mounting for parking access.....10
  - mounting options.....15
  - orientation.....10, 21
  - overhead mounting.....15
  - paint.....6
  - read range.....11
  - side-mounting.....16
  - specifications.....72
  - tag read indicator.....6
- antenna/reader connection.....24
- anti-passback.....12
- attenuation.....17
- Automatic Vehicle Identification (AVI).....1
- back-end host systems.....2, 5
- battery
  - Identity Flex transponder.....4
- baud rate.....36
- Belden 8240.....8, 17, 27
  - connectors.....18
- Belden 9913.....8, 17, 27
  - connectors.....18
- Belden 9913 Amphenol 82-202-1006
  - Installation.....32
- bit length.....39
- bracket mounting nuts.....25
- Break on Removal.....14
- buffer.....11
- cable connector
  - dimensions.....28
  - installation.....28
- cable routing.....16
- cable run.....8, 16
- California Transportation System
  - Title 21.....1, 3, 4
- coaxial cable
  - tips.....8
- coaxial cype N cable connector.....25
- common problems and solutions.....57
- communication cabling
  - run with antenna cabling.....17, 21
- component specifications.....71
- components.....63
- conduit.....8
  - diameter.....17, 27
  - installation.....27
  - selection.....17
- configuration setup.....19, 34, 35
- connectors.....8
- CPU Active.....50
- CPU Active LED.....27
- crimper.....8, 18, 28
- customized operation.....5
- data bits.....36
- data direction.....39
- dealer code.....4
- desktop reader.....15
- detecting loops.....5
- detector loop.....3
- diagnostic features.....56
- discrete I/O connector.....42
- discrete input polarity.....45
- discrete input/output functions.....45
- discrete input/output jumpers.....44
- discrete inputs and outputs.....35, 43
- Double Phase-Shift Keyed
  - modulation.....3
- downloading operational configuration
  - information.....35
- dry contact relay.....46
- dry contact relay output.....12
- Echo ABCD.....56
- electromagnetic interference.....17
- emulation.....36
- environmental conditions.....16
- equipment placement.....16
- error detection.....3
- external modems.....15
- external mount transponder.....4
  - adding to tag list.....55
  - description.....4
  - mounting.....53
  - specifications.....73
- facility code.....9, 15
- flow control.....36

- four-channel board
  - input specification.....65
  - output specification.....65
- gate input or loop input relays.....46
- gate open signal.....11
- gate output or lamp output relays.....47
- gate output relays.....14
- gated access systems.....12
- gates.....9
- glossary.....74
- hexadecimal format.....55
- host interface
  - connector and jumpers.....36
  - connector pin functions.....36
- Host RCV.....50
- identification number.....3, 4, 15
- IDentity Flex Reader
  - connections.....34
  - description.....5
- IDentity Flex Reader System
  - overview.....1
- IDentity Flex Remote Antenna.....See antenna
- IDentity Flex Software.....15
- IDentity Flex system
  - operation.....2
  - overview.....1
- IDentity Flex transponder.....4
  - family.....3
  - mounting**.....52
  - specifications.....72
- IDentity Title 21 (Tolling Application) Transponder
  - description.....4
- indicator LEDs.....50
- indicator lights.....49
- installation.....20
- Installation Tools.....19
- interface connections.....34
- Interface/Diagnostic Tools.....19
- internal buffer.....11
- internal data register.....3
- lane configurations.....9, 10
  - gated access.....12
  - parking access.....11
- lane controller.....2
- lane logic.....10, 11, 12
  - gated access.....14, 15
- LED feature.....6
- LED tag read indicator.....17, 28
- LEDs.....49
- legend.....25
- license plate holder.....4
- light curtains.....5
- local electrical regulations.....19
- maintenance computer.....5, 19, 34, 35
- maintenance interface.....34
- maintenance port.....35
- master.....41
- memory gate operation.....47, 49
- memory gates
  - gated access.....14
  - parking access.....11
- menu options.....56
- metal-oxide.....4, 6, 14
- metal-oxide windshields.....51
- mini-UHF connector.....18, 25
- multiple reader installations
  - gated access.....15
  - overview.....1
  - sync connections.....41
  - synchronization.....41
- NEMA 4X enclosure.....25
- no power.....57
- non-memory lift gate.....47
- non-memory lift gate operation.....48
- null modem cable.....19
- optical barrier.....47
- options.....63
- opto-isolated relay board.....46
- opto-isolated relay wiring guide.....65
- overhead mounting.....15
- overview.....1
- parity.....36
- Parking Access Systems.....10
- part numbers.....63, 64
- polling sequences.....49
- port LED.....50
- power output.....10
- power supply
  - reader.....5
- Pre-Installation Questionnaire.....9
- pull-up circuit.....39
- pulse width.....46
- Quick Power-On Test.....27
- read pattern.....6, 10, 12
- read range low.....59
- Read Tags and Display Results.....56
- read zone.....6, 10
  - gated access.....14
- reader
  - accessibility.....16
  - connections.....26, 34
  - description.....5
  - installation.....26
  - location.....16
  - no serial communication.....60
  - no Wiegand communication.....61
  - not functioning.....62
  - overview.....1
  - relay problems.....62
  - specifications.....71
- relay wiring guide.....65
- remote antenna.....See antenna, See antenna
- RF transmission.....51

- RG-58/U.....8, 17, 27
  - connectors.....18
- RG-58/U Amp 226600-1
  - Installation.....29
- RG-58U Amphenol 82-5375
  - Installation.....30
- RS-232.....35
- RS-422.....35
- RS-485.....35, 37
- security
  - reader location.....16
- security features.....14
- Security-Flex (S-Flex) Transponder
  - decsription.....4
- serial cable.....19, 35
- Serial Host Connections.....35
- serial numbers.....14
- S-Flex transponder
  - gated access.....14
  - mounting**.....52
  - specifications.....72
- short haul modems.....15
- side-mounting.....16
- signal strength.....6
- site planning.....9
- sixteen-channel board
  - input specification.....67
  - output specification.....68
  - terminals.....69
- slaves.....41
- smart switches.....15
- specifications.....71
- stop bits.....36
- Summary.....1
- sync cables.....41
- Sync Indicator.....50
- Sync Indicator LED.....27
- sync interface connector.....42
- sync termination jumpers.....42
- synchronization.....41
- system host interface.....36
- system interfaces.....34
- tag list.....6
- tag list file.....55
- Tag Read.....50
- tag read indicator.....6
- test hardware operation.....49
- Test Host Serial Port.....56
- Test RF Noise Detection.....56
- Test Static RF Power.....56
- Test SYNC Port.....56
- Test Wiegand Port.....56
- time delay.....46
- Title 21.....4
  - external mount.....4
  - programming.....4
  - tolling application transponder.....4
- Title 21 transponders.....15
  - conversion procedure.....55
  - gated access.....14
  - mounting.....54
- tolling application transponder
  - mounting.....54
- tolling application transponders
  - gated access.....14
- traffic flow.....12
- translation table.....2
- transponder
  - description.....3
  - external mount.....4, 51
  - IDentity Flex.....4
  - mounting.....52
  - no read.....58
  - overview.....2
  - S-Flex.....4
  - specifications.....72
  - testing.....51
  - Title 21.....4
  - usage.....51
- transponder reading locations
  - discrete outputs.....5
  - overview.....1
  - reader capability.....5
- transponder translation lists.....35
- trapped vehicle.....10, 11
- Trigger ABCD.....56
- troubleshooting.....6, 57
- truck fleet.....4
- TTL input/output.....1, 5
- U-Bolts.....25
- unauthorized vehicles.....14
- Universal Mounting Bracket.....6, 21
  - specifications.....72
- up-load operating software.....35
- vehicle detection loop
  - parking access.....12
- vehicle detection loops.....10
- vehicle identification.....3
- vehicle presence loops.....9
- vehicle speed.....10
- wake-up signal.....3
- Wiegand interface.....37
  - connector pin-outs.....38
  - jumper port layout.....38
  - specifications.....37
- Wiegand protocol.....5