

# TC30

## Ultrasonic Vehicle Presence Sensor for Vehicle Control

## INSTALLATION INSTRUCTIONS

### Section 1

#### General Description

The Model TC30 is a vehicular presence sensor designed to actuate a traffic controller. The TC30 operates on a principle called "Ultrasonic Ranging". A burst of ultrasonic energy is transmitted from the unit and, if an object is in the pattern, some of this energy is reflected back and detected. Once triggered, the relay will hold for as long as an object is within range plus the relay hold time delay (user adjustable from 0.25 to 10 seconds).

The TC30's pattern is conical in shape with maximum pattern dimensions of 22 feet by 5 feet. As the pattern distance is reduced, the width decreases accordingly. NOTE: When mounted correctly, the TC30 will cover one lane of traffic.

The TC30 must be mounted so that its pattern is at a right angle (perpendicular to) and looking directly at traffic flow, so ideal reflections are possible. We recommend an overhead mounting position (i.e., to an overhead sign mast, gantry, etc.) and a typical mounting height of 12 to 18 feet (See **Figures 1, 2 & 3**).

The TC30 has a red LED located on the back plate which provides a visual identification whenever the sensor detects a target. When installing overhead, use the LED to determine how far off the ground the sensor sees.

 **CAUTION:** if the range extends too far, it will always see the ground. We recommend the range to extend to approximately 2' to 3' off the ground.

#### APPLICATIONS:

- Traffic counter
- Input to software/counters/classifiers to count vehicular traffic
- Hold-open or egress device on automatic gate and toll booth applications
- In a number of applications in which loops would be used (excluding speed and axle classification)

### Section 2

#### Installation

##### Mounting

The TC30 can be mounted for either side-of-road or overhead detection. We recommend an overhead mount with a typical height of 12 to 18 feet off the ground. The unit may be banded to a pole or attached with two lag bolts through ½" prepunched holes in the mounting

bracket.



**CAUTION:** DO NOT MOUNT AT ANY ANGLE OTHER THAN 90 DEGREES (PERPENDICULAR TO TARGET), OTHERWISE, THE RETURN ECHO CAN BOUNCE AWAY FROM THE SENSOR AND MISS THE TARGET.



**CAUTION:** DO NOT MOUNT UNIT ON ITS SIDE OR UPSIDE DOWN. **UNIT MUST BE MOUNTED IN ITS UPRIGHT POSITION OR POINTING STRAIGHT DOWN.**

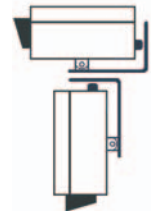

Following are two methods for installing TC30:

#### 1. Overhead (mast-arm or sign gantry) mount.

- Locate mast arm over lane to be covered.
- Mount unit (typically 12'-18' above pavement).
- Run a 4-conductor cable from the TC30 to the controller cabinet with two wires to power supply and two wires to counter / classifier / detector inputs.
- Aim unit straight down to the center of the lane being observed.
- Extend the range (by turning external range potentiometer clockwise) until the unit sees the road (the red LED will light).
- Back the range off so the unit will see objects 2-3 feet off the ground to allow for expansion and contraction of the pattern. The red LED should go out at this time (see **Fig. 1**).
- Refer to **Figure 1** for overhead mounting diagram.

#### 2. Side-of-road (parallel) mount.

- Locate or provide a pole near lane approach.
- Mount the unit (typically 3'-5' above ground).
- Run a 4-conductor cable from the TC30 to the controller cabinet with two wires to the power supply and two wires to the counter / classifier / detector inputs.
- Aim the unit so it "looks" directly at the side of (perpendicular to) any passing vehicle.
- Extend the range so pattern of detection extends to approximately half way through the lane.
- Refer to Figure 2 for side-fire mounting diagram.

**NOTE:** The nature of ultrasonic ranging technology requires a direct reflection from target for proper operation of the unit.

# TC30

## Ultrasonic Vehicle Presence Sensor for Vehicle Control

## INSTALLATION INSTRUCTIONS

### Wiring—(see wiring diagram)

Operating voltage is 12V to 24V AC or 6V to 12V DC. AC voltages are usually supplied through a transformer while DC voltages are supplied with a battery or transformer. Current consumption of the TC30 is 250mA. **NO AMPLIFIER REQUIRED!**



**CAUTION:** Due to an internal heater, a current surge will occur upon power-up. If connecting multiple sensors to one transformer, the **transformer MUST BE rated for 1 Amp per sensor.**

**NOTE:** A 24V, 24VA transformer, for providing power to one unit, is included with sensor.



**WARNING:** To limit exposure to electrical damage from power surges, ALWAYS wire the sensor through the transformer that is provided or a TCPS series isolation module (sold separately).

To wire, remove the cover of the TC30. This is accomplished by removing the four (4) hex head machine screws, two (2) of which are located on each end of the sensor (on the front and back plates). The cover is removed by lifting up slightly and sliding it forward. This exposes the terminal strip.

**Power Connections**—Applying power to the TC30 is accomplished in two steps. First, determine which terminals to use by looking at the Voltage Switch Options chart in **Figure 4** (wiring diagram) or located inside the sensor's casing. Terminal 3 will always be used as a ground (for DC supplies) or common (for AC supplies). Second, with power off, complete the following:

1. Slide the Voltage Option Switch to its indicated position.
2. Connect wiring to the terminal strip.
3. Apply power.

**CAUTION:** Do NOT apply 120V AC primary power to the transformer until all secondary wiring is complete.



**WARNING:** Do Not ground one side of the secondary of the supply transformer. Circuit ground of the unit is electrically connected to the housing. Grounding one side of the transformer may create a direct short that will permanently damage the unit.



**WARNING:** If Voltage Option Switch is in the wrong position when power is applied, severe damage to the unit may occur.

**Use a 4-conductor cable, 18 to 22 gauge conductor size, 3/16" to 5/16" cable O.D. Ensure that the transformer secondary output is isolated from neutral or ground.**

### NOTE:

1. The connector is designed for wire with a jacket between 3/16" and 5/16" O.D. If wire is smaller, seal the wire fitting with sealant.
2. No wire larger than 18 gauge should be used. The terminal block is not large enough to accept wire larger than this.

After wiring is complete, reattach the cover and ensure that all bolts, screws, and cable fittings are installed and tight to prevent water damage. *For more information, call us toll-free at (800) 842-2545.*

### Alignment

The TC30's alignment is accomplished by adjusting the EXTERNAL Range Potentiometer. The range potentiometer sets the distance at which the sensor can detect an object.



**NOTE:** All MS SEDCO's potentiometers are one turn only and as follows: Clockwise to maximum, Counterclockwise to minimum.

The pattern is cone shaped and the width will vary proportionately with the range adjustment. See pattern diagrams (**Figure 1, 2 & 3**) for more information on pattern dimensions.

### Operation

An External LED, on the back plate of the unit, provides a visual indication each time the sensor's relay changes state (unit detects a target). The relay contacts are Form C and rated at 5 amps. A 2nd adjustment (Relay Hold Time Potentiometer) allows the relay to be held from 1/4 to 10 seconds after the target has left the unit's detection pattern.

This feature can be used in situations where a longer reset time is desired. The LED can also be used when setting the time delay to provide a visual indication of how long the relay is delayed.

# TC30

## Ultrasonic Vehicle Presence Sensor for Vehicle Control

## INSTALLATION INSTRUCTIONS

### Section 3

#### Technical Data

Model.....TC30  
Frequency.....49.7 kHz  
Detection Pattern.....Adjustable Ranges  
(without removing cover)  
See **Figure 2** for patterns  
Pattern.....approx. 12° beam width  
(at 22' the pattern is approx.  
5' wide)  
Detection Angle.....Adjustable, Horizontal &  
Vertical  
Detection Hold Time.....Continuous upon sensing  
Relay Hold Time.....Adjustable 0.25 to 10 sec.  
Power Requirements.....12V to 24V AC or  
6V to 12V DC  
Current Consumption.....250mA  
Relay Contacts.....Form C, rated at 5 amps  
Mounting.....Heavy-duty bracket, predrilled &  
slotted for pole mount  
Temperature.....-35°F to 165°F  
(-37°C to 75°C)  
Weight.....3 lbs. (1.6kg) approx.  
Size.....9" x 4" x 4"  
(23cm x 10.2cm x 10.2cm)  
Color.....Gray powder coat  
Enclosure.....Aluminum with stainless steel  
hardware

**\*\* NOTE: Due to an internal heater, a current surge will occur upon power-up. If connecting multiple sensors to one transformer, the transformer MUST BE RATED FOR 1 AMP PER SENSOR MINIMUM!**

### Section 4

#### Warranty

MS SEDCO guarantees this product to be free from manufacturing defects for one year from date of installation. Unless MS SEDCO is notified of the date of installation, the warranty will be in effect for one year from the date of shipment from our factory. If, during the first year, this device fails to operate and has not been tampered with or abused, the unit can be returned prepaid to the factory and it will be repaired free of charge. After one year, the unit will be repaired for a nominal service charge. **This limited warranty is in lieu of all other warranties, expressed or implied, including any implied warrantability of merchantability, and no representative or person is authorized to assume for MS SEDCO any other liability in connection with the**

sale of our products. All warranties are limited to the duration of this written limited warranty. In no event shall MS SEDCO be liable for any special, incidental, consequential or other damages arising from any claimed breach of warranty as to its products or service.



FIGURE 1

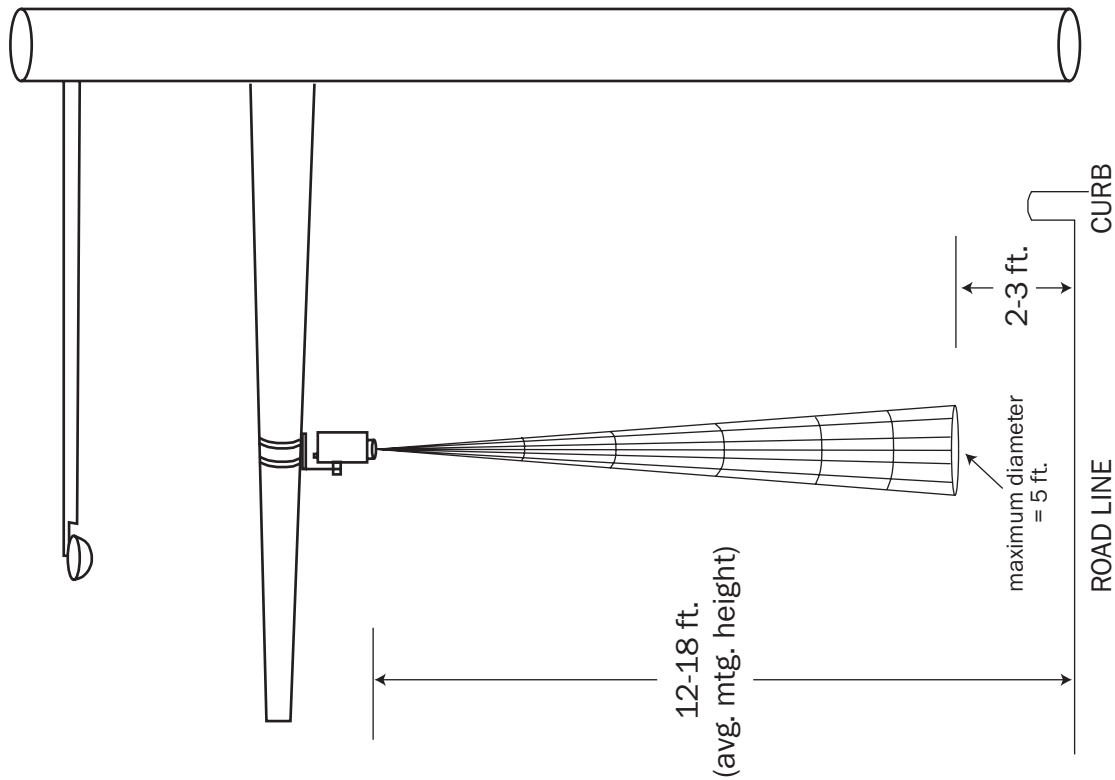

NOTES:

1. Adjust unit so it looks into the center of the lane being observed.
2. Extend the range (by turning the range potentiometer clockwise) until the unit sees the road (red LED will light).
3. Back the range off so the unit sees objects 2-3 ft. off the ground (red LED should go off).

\*\* MS SEDCO suggests placing a 3' high temporary target (like a cardboard box) in the lane and adjusting the range to lock onto it. By doing this, you will attain the desired detection pattern.

FIGURE 2

**CORRECT sidefire mounting method**

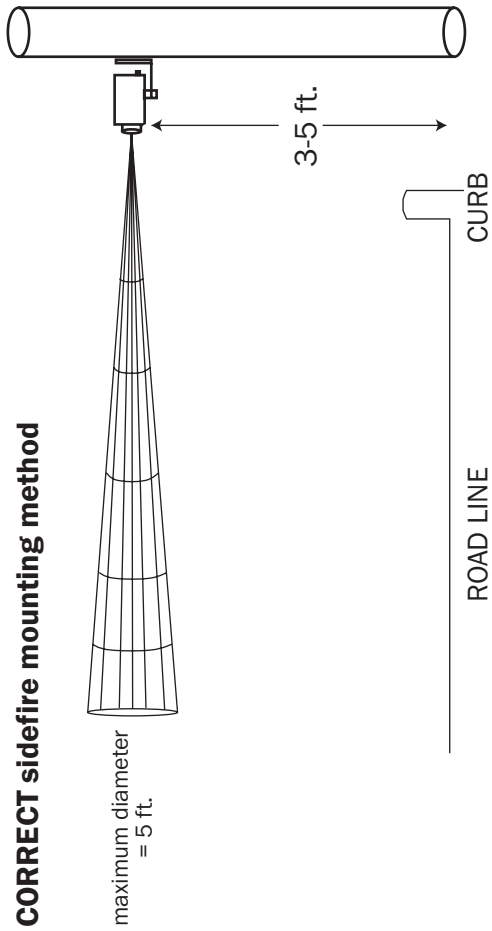

- NOTES:
1. Locate or provide pole near lane approach.
  2. Mount the unit 3-5 ft. above the ground. Be sure the unit is aimed so it "looks" at the side of any vehicle that passes by.
  3. Extend the range so the pattern of detection extends to approximately half way through the lane.

**INCORRECT sidefire mounting method**

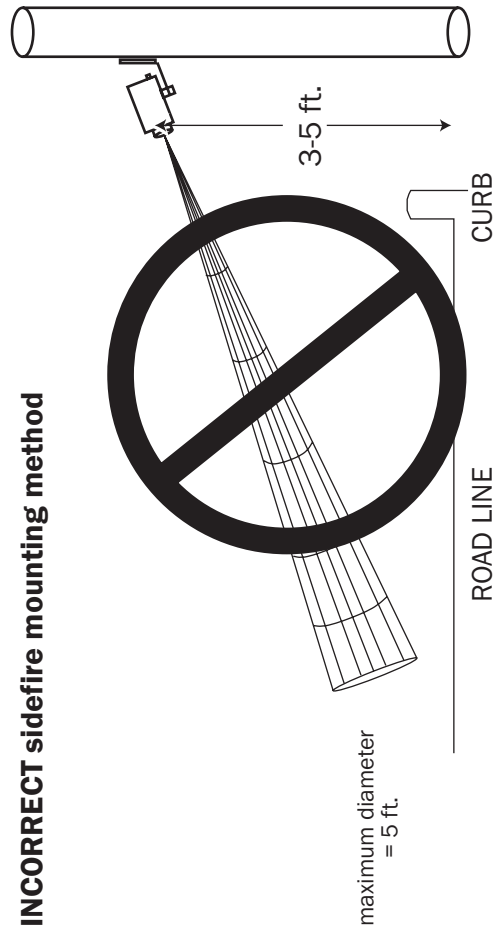

- NOTES:
1. Although this mounting scheme would deter potential vandals, it is not recommended for presence detection.
  2. Any part of the pattern hitting a target can bounce away from the sensor causing missed targets or inaccurate speed readings.

FIGURE 3

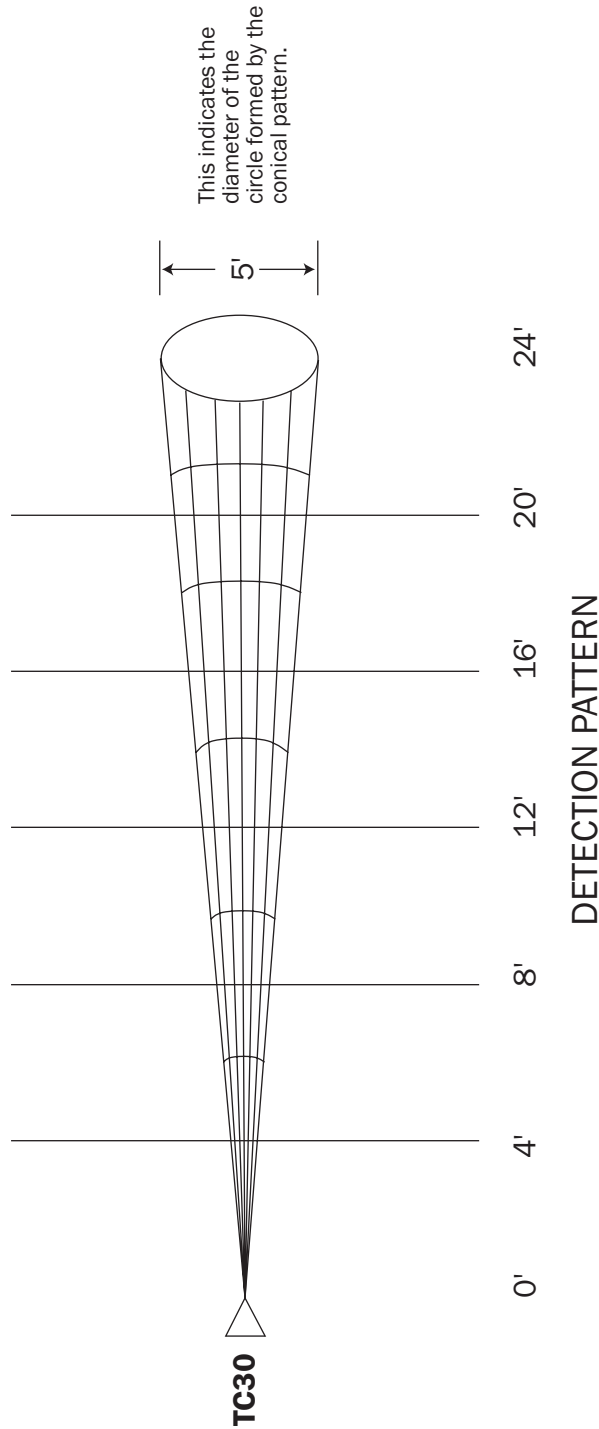

NOTES:

1. Pattern shown is approximate.
2. Adjust each sensor to assure proper reporting. The pattern is adjusted by turning the EXTERNAL Range Potentiometer.
3. Minimum range is 7 ft. All objects within 7 ft. of the sensor will be detected.
4. Pattern shape is conical.
5. See the installation instructions for more detailed information.

\*\* MS SEDCO suggests placing a 3' high temporary target (like a cardboard box) in the lane and adjusting the range to lock onto it. By doing this, you will attain the desired detection pattern.

FIGURE 4

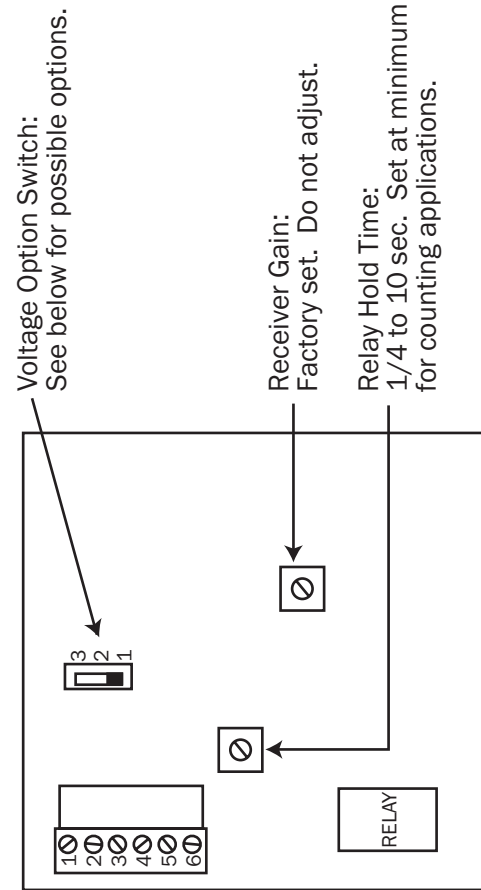

### Power Inputs

See below for options.  
Terminal 3 is always ground or common.

### Relay Connections

- 4 = Normally Open (N.O.)
- 5 = Common
- 6 = Normally closed (N.C.)

### NOTE:

Relay is with power applied

### LED Indicator

The LED is illuminated when the sensor is detecting a target.

### Voltage Switch Options

Terminals	Voltage	Position
1 & 3	24V AC	3
2 & 3	12V AC	3
2(+) & 3(-)	8-12V DC	2
2(+) & 3(-)	6-8V DC	1

### To Use:

Determine which terminals to use based on your supply voltage. Move the voltage option switch to the correct position.

Apply power.

\*\*\*WARNING\*\*\*

If the voltage option switch is in the wrong position when power is applied, severe damage to the unit may result.