

ELECTROMAGNETIC DOOR HOLDER

The EBELCO electromagnetic door holders are renown with its excellent reliability in fail-safe operation and the remarkable features.

The products are compliance to CE and are manufactured under the highest quality control to achieve the commitment to customer who always satisfied with maximum quality and reliability.

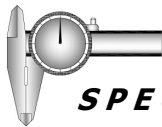

SPECIFICATIONS:

- ▶ **Voltage Input :** 12 VDC / 24 VDC
- ▶ **Current Draw :** 12V / 80mA ; 24V / 40mA (±5%)
- ▶ **Holding Force :** Up to 110 lbs (50 kg)
- ▶ **Anti-Rust Surface Treatment :** Blue Zinc Plating
- ▶ **Operating Temperature :** 0~55° C (32~131° F)
- ▶ **Operating Humidity :** 0~95% (non condensing)
- ▶ **Weight :** 0.6 kg (±1%)
- ▶ **Dimensions :** Magnet - (Hori)250mm,(Verti)220mm
Armature - (Φ)55x(T)8 mm



FEATURES:

- ▶ **Dual Voltage Selectable (12 VDC or 24 VDC)**
- ▶ **Emergency Release Button / Test Button**
- ▶ **Floor and Wall Mounting Direction**
- ▶ **Low Current Consumption**
- ▶ **Reliable Fail-Safe Mechanism**
- ▶ **Durable and Silence Operation**
- ▶ **Cosmetic Powder Coat Casing**
- ▶ **Compact Size for Most Type of Swing Doors**
- ▶ **Anti-Residual Magnetism Kick Off Button**

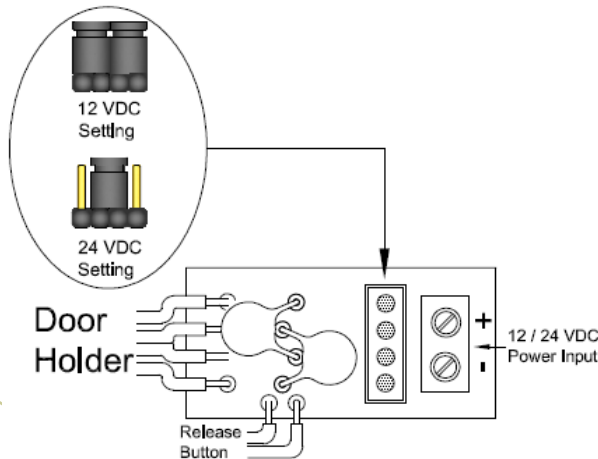

IMPORTANT!

Set the jumper position according to the power Input correctly before switch ON the power.

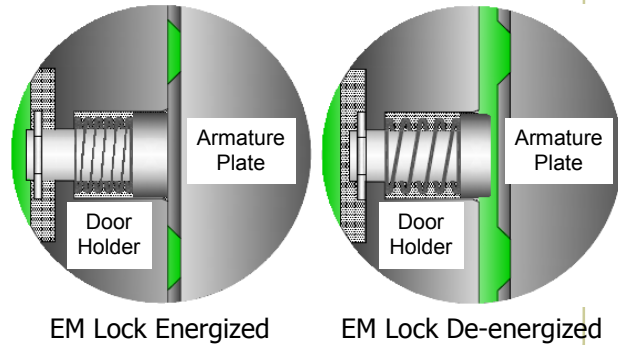

Disclaimer :

EBELCO reserve the right to go ahead with any modifications of models or features or price without forewarning. All the information and specifications stated in this document are current at the time of publication.

SECURITY . QUALITY . RELIABILITY